

# Fluid control valve(2/2 way)

## 2KSA Series (Direct-acting and normally opened)



### Symbol



### Product feature

1. Direct acting and normally opened type 2/2 way fluid valve. Its high sensibility allows it to change direction quickly;
2. It has wide pressure range, including extra high pressure (X), high pressure (H), standard and large volume(L);
3. It is compact, small size and light weight. Easy to install and dismantle.
4. The valve body is made of SUS304. Its coil has a Heat resistance classification of Class F. The standard seal material is FPM-F. Please contact us if other seal material are required.
5. The protection class of the coil is IP65 and there is a choice for grommet or terminal electrical entry.

### Specification

Model/Item	Port size [Note1]	Orifice size (Φmm)	Cv	Valid area or section(mm <sup>2</sup> )	Weight [Note2](g)	Max.operating pressure differentia		Proof pressure	
						MPa	psi	MPa	psi
2KSAX030	-06 1/8"	1.5	0.10	1.8	245	2.0	300	3.0	450
	-08 1/4"				235				
2KSAH030	-06 1/8"	2.0	0.18	3.0	245	1.5	220	3.0	450
	-08 1/4"				235				
2KSA030	-06 1/8"	3.0	0.33	6.0	245	0.7	100	3.0	450
	-08 1/4"				235				
2KSAL030	-06 1/8"	4.0	0.55	10.0	245	0.4	60	3.0	450
	-08 1/4"				235				
2KSAX050	-10 3/8"	3.0	0.34	6.1	530	2.0	300	3.0	450
	-15 1/2"				510				
2KSAH050	-10 3/8"	4.0	0.55	10.0	530	1.5	220	3.0	450
	-15 1/2"				510				
2KSA050	-10 3/8"	5.0	0.83	15.0	530	0.7	100	3.0	450
	-15 1/2"				510				
2KSAL050	-10 3/8"	7.0	1.40	25.0	530	0.4	60	3.0	450
	-15 1/2"				510				

[Note1] PT thread, G thread and NPT thread are available.

[Note2] The weight in the table is the terminal valve's weight, 2KSA030 series grommet valve's weight is 10g less than terminal's. 2KSA050series grommet valve's weight is 20g less than terminal's.

### Inner structure

#### 2KSA030(Terminal)

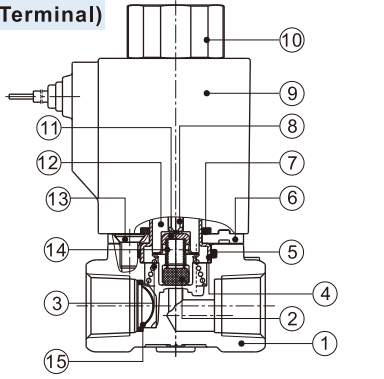

No.	Item	No.	Item	No.	Item
1	Body	6	Fixed plate	11	Airtight bush
2	Airtight ring	7	O-ring	12	Electromagnet
3	Spring	8	Mandril	13	Screw
4	Coil axis	9	Coil assembly	14	Spring
5	O-ring	10	Coil nut	15	Filter

### Specification of coil

Valve type	Coil type	Power type	Frequency (Hz)	Voltage range	Electrical entry	Power Consumption (VA/W)	Insulation	Temp. rise(°C)
2KSA□030	CDA110 CLA110	AC	50	±15%	Terminal (CDA)	15.0VA	Class F	50
			60			11.0VA		45
		DC	-	±10%		6.5W		50
2KSA□050	CDA160 CLA160	AC	50	±15%	Grommet (CLA)	35.0VA	Class F	65
			60			30.0VA		60
		DC	-	±10%		12.0W		50

### Valve's specification

Acting		Direct acting				
Initial state		Normally opened				
Adaptable fluid		Air, Water, Oil				
Viscosity limit		Under 20CST				
Ambient and fluid temperature ( °C )		Water	Air	Oil	Ambient	
		Max. 80	90	80	70	
		Min. 1	-20 [Note1]	-10 [Note2]	-20	

[Note1] Dew point: -20(°C) or less ;

[Note2] 50CST or less.

### Ordering code

#### Ordering code of valves

2KSA H 030 08 A □ G



① Model	② Pressure condition	③ Size series	④ Port size	⑤ Voltage	⑥ Electrical entry	⑦ Thread type
2KSA: 2/2 way direct-acting and normally opened	X: Extra high pressure H: High pressure Blank: Standard L: Large volume	030: 030 Series 050: 050 Series	06: 1/8" 08: 1/4" 10: 3/8" 15: 1/2"	A: AC220V B: DC24V C: AC110V E: AC24V F: DC12V	Blank: Terminal I: Grommet[Note]	G: G

[Note] The wire length is 0.5m.

#### Ordering code of accessories

Ordering code of accessories is the same as 2WA series valve's, Please refer to P19 for details of ordering code.

# Fluid control valve(2/2 way)

## 2KSA Series (Direct-acting and normally opened)

### Flow chart

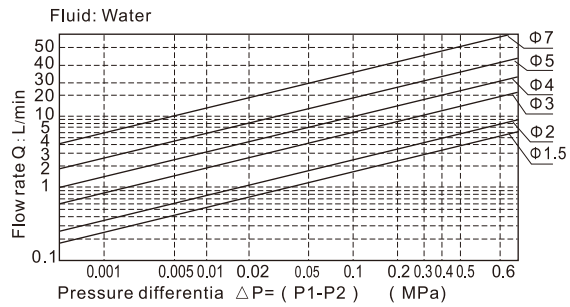
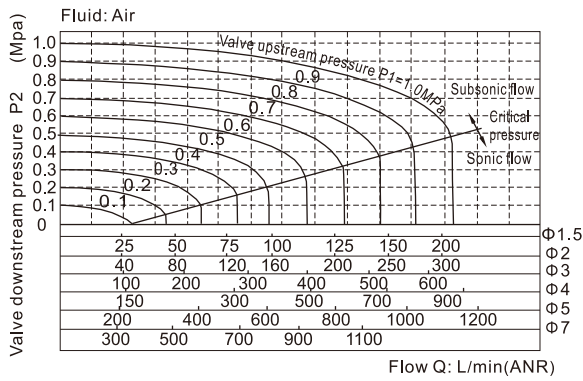

### Dimensions

#### 2KSA□030 (Terminal)

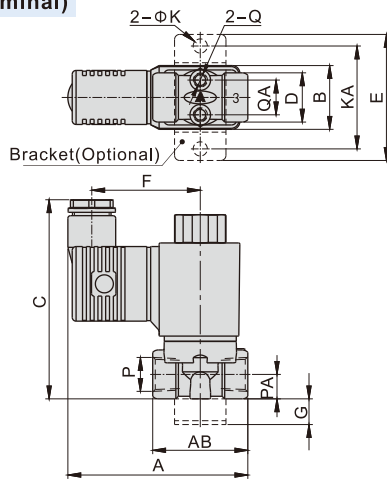

#### 2KSA□030 (Grommet)

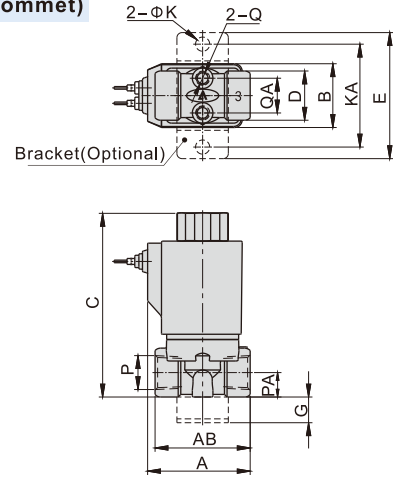

#### 2KSA□050 (Terminal)

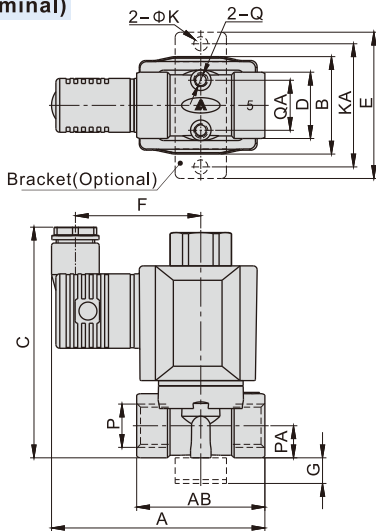

#### 2KSA□050 (Grommet)

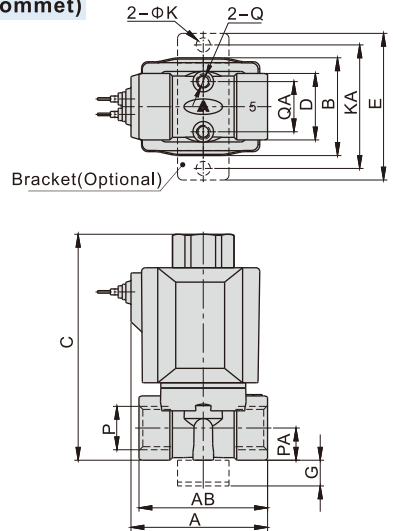

Model\Item	A	AB	B	C	D	E	F	G	K	KA	P	PA	Q	QA
2KSA□030-06	70	37	25	77.5	19	49	42	10	5.5	40	1/8"	9.5	M5	13.5
2KSA□030-08	70	37	25	77.5	19	49	42	10	5.5	40	1/4"	9.5	M5	13.5
2KSA□050-10	83	50	38	90	26	57	49	10	5.5	48	3/8"	12.5	M5	19.5
2KSA□050-15	83	50	38	90	26	57	49	10	5.5	48	1/2"	12.5	M5	19.5

Model\Item	A	AB	B	C	D	E	G	K	KA	P	PA	Q	QA
2KSA□030-06	40	37	25	74	19	49	10	5.5	40	1/8"	9.5	M5	13.5
2KSA□030-08	40	37	25	74	19	49	10	5.5	40	1/4"	9.5	M5	13.5
2KSA□050-10	53	50	38	90	26	57	10	5.5	48	3/8"	12.5	M5	19.5
2KSA□050-15	53	50	38	90	26	57	10	5.5	48	1/2"	12.5	M5	19.5

# Fluid control valve(2/2 way)

## 2KSA Series (Internally piloted and normally opened )



### Symbol



### Product feature

1. Indirect acting (Internal pilot) and normally opened type 2/2 way fluid valve. Its can change direction quickly and has large flow.
2. It is compact, small and light weight. Easy to install and dismantle;
3. The valve body is made of SUS304 . The coil has a Heat resistance classification of Class F. The standard seal material is FPM-F. Please contact us if other seal material are required.
4. The protection class of the coil is IP65 and there is a choice for grommet or terminal electrical entry .

### Specification

Model\Item	Port size [Note1]	Orifice size (Φmm)	Cv	Valid area or section (mm <sup>2</sup> )	Weight [Note2](g)	Operating pressure differentia		Proof pressure	
						MPa	psi	MPa	psi
2KSA150-15	1/2"	15.0	5.50	100.0	575	Max:0.7 Min:0.05	Max:100 Min:10	1.5	220
2KSA200-20	3/4"	20.0	9.50	170.0	735				
2KSA250-25	1"	25.0	12.50	220.0	1035				
2KSA320-32	1 1/4"	32.0	23.00	420.0	2287				
2KSA400-40	1 1/2"	40.0	31.00	560.0	2677				
2KSA500-50	2"	50.0	49.00	880.0	3557				

[Note1] PT thread, G thread and NPT thread are available.  
[Note2] The weight in the table is the terminal valve's weight,  
Grommet valve's weight is 10g less than terminal's.

### Specification of coil

Valve type	Coil type	Power type	Frequency (Hz)	Voltage range	Electrical entry	Power Consumption (VA/W)	Insulation	Temp. rise(°C)	
2KSA150	CDA110	AC	50	±15%	Terminal (CDA)	15.0VA	Class F	50	
2KSA200			60			11.0VA		45	
2KSA250	DC	-	±10%	6.5W		50			
2KSA320				50		35.0VA		65	
2KSA400	CDA160	AC	60	±15%		Grommet (CLA)		30.0VA	60
2KSA500	CLA160	DC	-	±10%				12.0W	50

### Valve's specification

Acting		Internally piloted			
Initial state		Normally opened			
Adaptable fluid		Air, Water, Oil			
Viscosity limit		Under 20CST			
Ambient and fluid temperature ( °C )		Water	Air	Oil	Ambient
	Max.	80	90	80	70
	Min.	1	-20 [Note1]	-10 [Note2]	-20

[Note1] Dew point: -20(°C) or less ; [Note2] 50CST or less.

### Inner structure

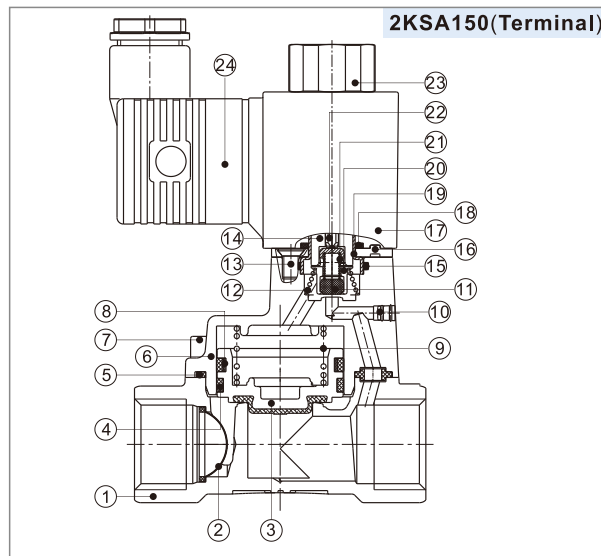

No.	Item
1	Body
2	Filter
3	Piston
4	Wear ring
5	O-ring
6	Cover
7	Screw
8	Spring
9	Spring
10	Spacer
11	Airtight ring
12	Spring
13	Screw
14	Movable core
15	O-ring
16	Fixed plate
17	Coil assembly
18	O-ring
19	Coil axis
20	Airtight ring
21	Spring
22	Man drill
23	Coil nut
24	Connector

### Ordering code

#### Ordering code of valves

2KSA 150 15 A □ G

① ② ③ ④ ⑤ ⑥

① Model	② Orifice size	③ Port size	④ Voltage	⑤ Electrical entry	⑥ Thread type
2KSA: 2/2 way internally piloted and normally opened	150: Φ15mm	15: 1/2"	A: AC220V B: DC24V C: AC110V E: AC24V F: DC12V	Blank: Terminal I: Grommet [Note]	G: G
	200: Φ20mm	20: 3/4"			
	250: Φ25mm	25: 1"			
	320: Φ32mm	32: 1 1/4"			
	400: Φ40mm	40: 1 1/2"			
	500: Φ50mm	50: 2"			

[Note] The wire length is 0.5m.

#### Ordering code of accessories

Ordering code of accessories is the same as 2WA series valve's, Please refer to P21 for details of ordering code.

# Fluid control valve(2/2 way)

## 2KSA Series (Internally piloted and normally opened)

### Flow chart

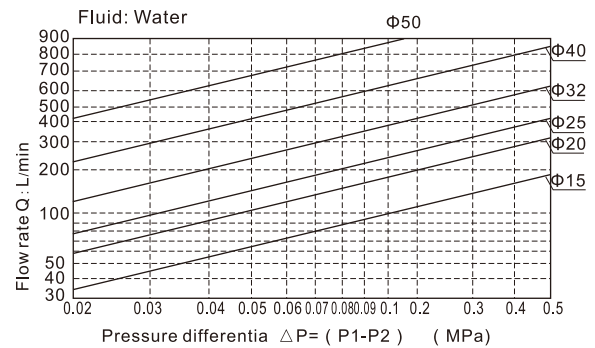
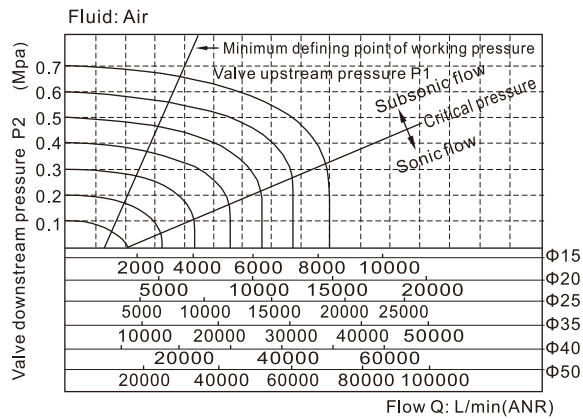

### Dimensions

#### 2KSA150~250 (Terminal)

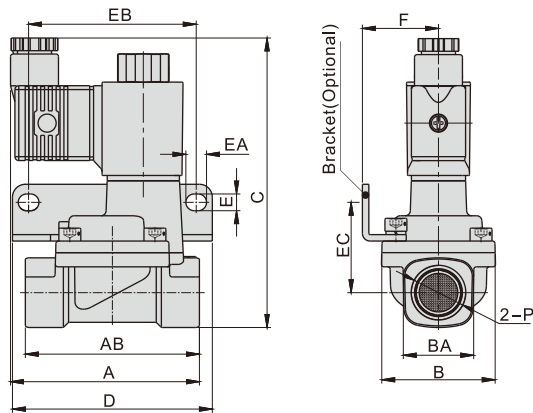

#### 2KSA150~250(Grommet)

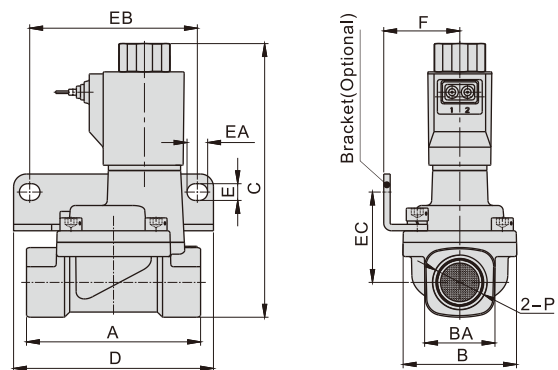

#### 2KSA320~500 (Terminal)

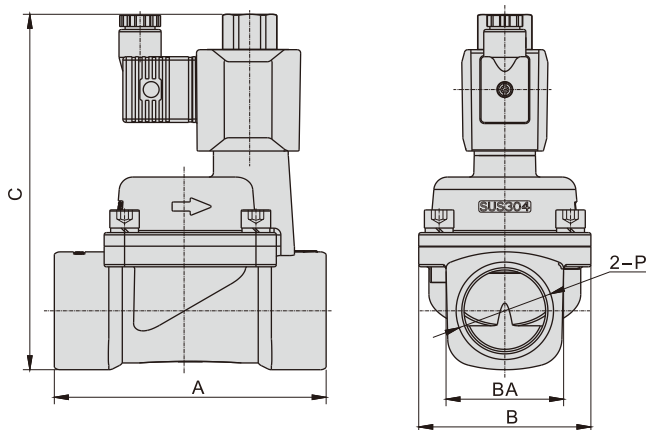

#### 2KSA320~500(Grommet)

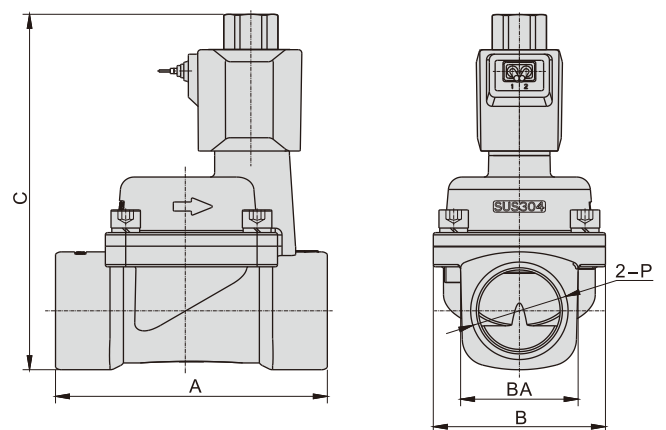

Model\Item	A	AB	B	BA	C	D	E	EA	EB	EC	F	P
2KSA150-15	73.5	67.5	44	27.5	112	77.5	6.5	8	65	35	29.5	1/2"
2KSA200-20	75.5	79.5	51	33.5	119	87.5	6.5	8	75	38	33	3/4"
2KSA250-25	77.5	90	57	40.5	126	93	6.5	8	80	42	35	1"
2KSA320-32	120	-	76	52	165.5	-	-	-	-	-	-	1 1/4"
2KSA400-40	126	-	86	58	175.5	-	-	-	-	-	-	1 1/2"
2KSA500-50	144	-	96	70	186.5	-	-	-	-	-	-	2"

Model\Item	A	B	BA	C	D	E	EA	EB	EC	F	P
2KSA150-15	67.5	44	27.5	109	77.5	6.5	8	65	35	29.5	1/2"
2KSA200-20	79.5	51	33.5	116	87.5	6.5	8	75	38	33	3/4"
2KSA250-25	90	57	40.5	123	93	6.5	8	80	42	35	1"
2KSA320-32	120	76	52	156.5	-	-	-	-	-	-	1 1/4"
2KSA400-40	126	86	58	164.5	-	-	-	-	-	-	1 1/2"
2KSA500-50	144	96	70	179.5	-	-	-	-	-	-	2"