

# Fluid control valve(2/2 way)

## 2L Series (Internally piloted and normally closed)



### Symbol



### Product feature

1. Indirect acting (Internal pilot) and normally closed type 2/2 way solenoid valve. Its high sensibility allows it to change direction quickly.
2. It is compact, small size and light weight. It is easy to install and dismantle.
3. The valve body is made of SUS304. Its coil has a Heat resistance classification of Class H. The standard seal material is PTFE (Teflon) which is suitable for a variety of working medium such as water with high temperature and vapour.
4. The protection class of the coil is IP65 and there is a choice for grommet or terminal electrical entry.

### Inner structure

**2L150 (Grommet)**

No.	Item
1	Body
2	Fixed ring
3	Airtight gasket
4	O-ring
5	Wear ring
6	Gasket
7	Screw
8	Spring
9	Cover
10	Spring
11	Screw
12	Spring
13	Spring washer
14	Coil assembly
15	Washer
16	E Clip
17	Movable core
18	Fixed plate
19	O-ring
20	Fixed cap
21	Airtight ring
22	Plug
23	Spring
24	Piston
25	Spacer
26	O-ring

### Ordering code

#### Ordering code of valves

2L 150 15 A □ G  
 ① ② ③ ④ ⑤ ⑥

① Model	② Orifice size	③ Port size	④ Voltage	⑤ Electrical entry	⑥ Thread type
2L : 2/2 way internally piloted and normally closed	150: Φ15mm	15: 1/2"	A: AC220V B: DC24V C: AC110V E: AC24V F: DC12V	Blank: Terminal I: Grommet[Note]	G: G Thread
	200: Φ20mm	20: 3/4"			
	250: Φ25mm	25: 1"			
	320: Φ35mm	32: 1 1/4"			
	400: Φ40mm	40: 1 1/2"			
500: Φ50mm	50: 2"				

#### Ordering code of accessories

Ordering code of accessories is the same as 2S series valve's, please refer to P184 for details of ordering code.  
 [Note] 320\400\500 series valves do not have mounting accessories.

[Note] The wire length is 0.5m.

### Specification

Model\Item	Port size [Note1]	Orifice size (Φmm)	Cv	Valid area or section (mm <sup>2</sup> )	Weight [Note2](g)	Operating pressure differential		Proof pressure	
						MPa	psi	MPa	psi
2L150-15	1/2"	15.0	5.50	100.0	675	Max: 1.0 Min: 0.05	Max: 150 Min: 10	1.5	220
2L200-20	3/4"	20.0	9.50	170.0	875				
2L250-25	1"	25.0	12.50	220.0	1120				
2L320-32	1 1/4"	35.0	23.00	420.0	2700				
2L400-40	1 1/2"	40.0	31.00	560.0	3250				
2L500-50	2"	50.0	49.00	880.0	4300				

[Note1] G thread is available.

[Note2] The weight in the table is the terminal valve's weight, 2L150~250series grommet valve's weight is 10g less than terminal's. 2L320~500series grommet valve's weight is 20g less than terminal's.

### Specification of coil

Valve type	Coil type	Power type	Frequency (Hz)	Voltage range	Electrical entry	Power Consumption (VA/W)	Insulation	Temp. rise(°C)
2L150 2L200 2L250	CDA116 CLA116	AC	50	± 15%	Terminal (CDA) Grommet (CLA)	10.0VA	Class H	35
			60			8.0VA		30
2L320 2L400 2L500	CDA170 CLA170	AC	50	± 15%		6.5W		30
			60			25.0VA		60
		DC	—	± 10%		22.0VA		55
			—			12.0W		40

### Valve's specification

Acting	Internally piloted				
Initial state	Normally closed				
Adaptable fluid	Steam, High temperature Water, Oil				
Viscosity limit	Under 20CST				
Ambient and fluid temperature (°C)		Oil	Water	Steam	Ambient
	Max.	150	150	183	100
	Min.	-10 [Note1]	1	—	-20

[Note1] 50CST or less.

# Fluid control valve(2/2 way)

## 2L Series (Internally piloted and normally closed)

### Flow chart

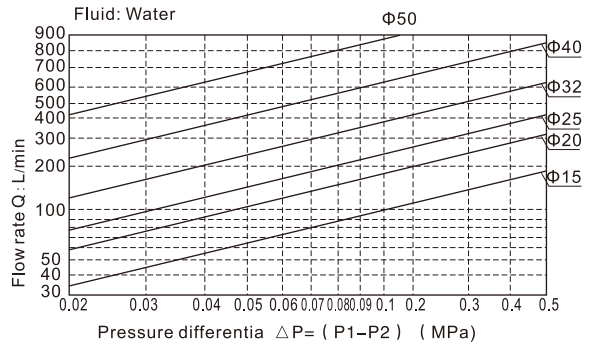
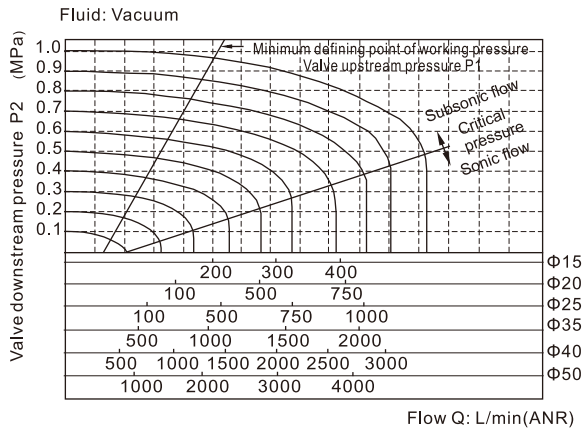

### Dimensions

#### 2L150~250(Terminal)

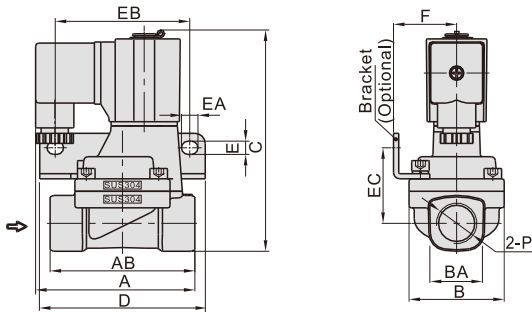

#### 2L150~250(Grommet)

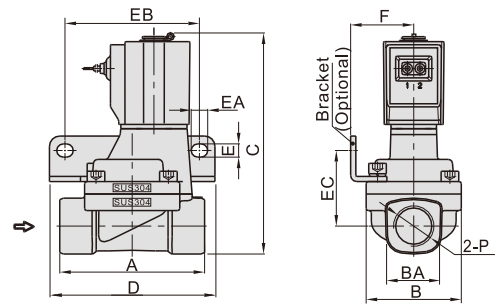

#### 2L320~500(Terminal)

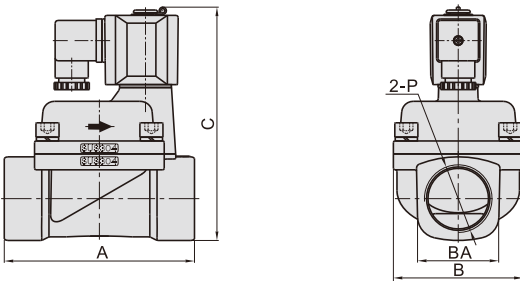

#### 2L320~500(Grommet)

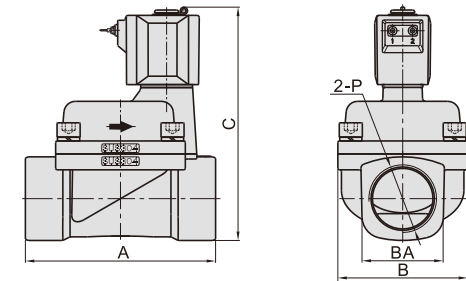

Model/Item	A	AB	B	BA	C	D	E	EA	EB	EC	F	P
2L150-15	77	70	46	27.5	107	80	6.4	8	65	36.5	30.5	1/2"
2L200-20	78.5	82	53	33.5	115.5	90	6.4	8	75	40	34	3/4"
2L250-25	81	92	59	40.5	124	95	6.4	8	80	44.5	36	1"
2L320-32	125	-	80	52	154.5	-	-	-	-	-	-	1 1/4"
2L400-40	132	-	90	58	162	-	-	-	-	-	-	1 1/2"
2L500-50	150	-	100	70	177	-	-	-	-	-	-	2"

Model/Item	A	B	BA	C	D	E	EA	EB	EC	F	P
2L150-15	70	46	27.5	107	80	6.4	8	65	36.5	30.5	1/2"
2L200-20	82	53	33.5	115.5	90	6.4	8	75	40	34	3/4"
2L250-25	92	59	40.5	124	95	6.4	8	80	44.5	36	1"
2L320-32	125	80	52	154.5	-	-	-	-	-	-	1 1/4"
2L400-40	132	90	58	162	-	-	-	-	-	-	1 1/2"
2L500-50	150	100	70	177	-	-	-	-	-	-	2"