

Fluid control valve(2/2way)

2W Series (Internally piloted and normally closed)



Symbol



Product feature

1. Indirect acting (Internal pilot) and normally closed type 2/2 way solenoid valve. Its can change direction quickly and has large flow.
2. It is compact, small and light weight. It is easy to install and dismantle;
3. The valve body is made of brass. The coil has a Heat resistance classification of Class B. The standard seal material is FPM-F. Please contact us if other material are required.
4. The protection class of the coil is IP65 and there is a choice for grommet or terminal electrical entry.

Specification

Model\Item	Port size [Note1]	Orifice size (Φmm)	Cv	Valid area or section (mm ²)	Weight [Note2](g)	Operating pressure differential		Proof pressure	
						MPa	psi	MPa	psi
2W150-15	1/2"	15.0	5.50	100.0	720	Max: 1.0 Min: 0.05	Max: 150 Min: 10	1.5	220
2W200-20	3/4"	20.0	9.50	170.0	950				
2W250-25	1"	25.0	12.5	220.0	1200				

[Note1] G thread is available.

[Note2] The weight in the table is the terminal valve's weight, grommet valve's weight is 10g less than terminal's.

Specification of coil

Valve type	Coil type	Power type	Frequency (Hz)	Voltage range	Electrical entry	Power Consumption (VA/W)	Insulation	Temp. rise(°C)
2W150	CDA116 CLA116	AC	50	± 15%	Terminal (CDA) Grommet (CLA)	10.0VA	Class B	35
2W200			60			8.0VA		30
2W250	DC	-	± 10%	6.5W	30			

Valve's specification

Acting		Internally piloted			
Initial state		Normally closed			
Adaptable fluid		Air, Water, Oil			
Viscosity limit		Under 20CST			
Ambient and fluid temperature (°C)		Water	Air	Oil	Ambient
	Max.	80	90	80	70
	Min.	1	-20 [Note1]	-10 [Note2]	-20

[Note1] Dew point: -20(°C) or less;

[Note2] 50CST or less.

Inner structure

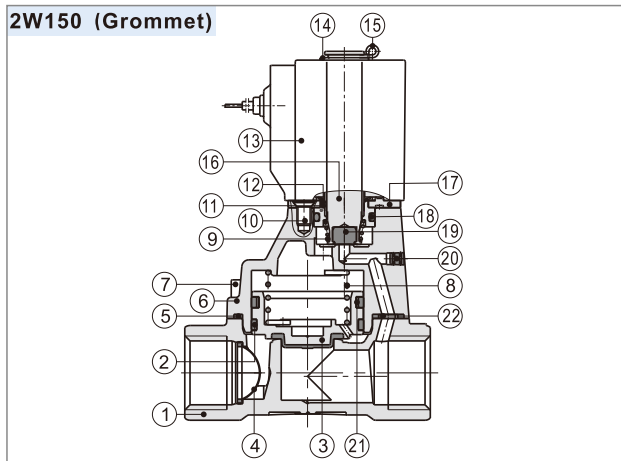

No.	Item	No.	Item	No.	Item
1	Body	9	Spring	16	Movable core
2	Filter	10	Screw	17	Fixed plate
3	Piston	11	Fixed cap	18	O-ring
4	Wear ring	12	Washer	19	Airtight ring
5	O-ring	13	Coil assembly	20	Plug
6	Cover	14	Washer	21	Spring
7	Screw	15	E Clip	22	Spacer
8	Spring				

Ordering code

Ordering code of valves

2W 150 15 A □ G

① ② ③ ④ ⑤ ⑥

① Model	② Orifice size	③ Port size	④ Voltage	⑤ Electrical entry	⑥ Thread type
2W: 2/2 way internally piloted and normally closed	150: Φ15mm	15: 1/2"	A: AC220V B: DC24V C: AC110V E: AC24V F: DC12V	Blank: Terminal I: Grommet[Note]	G: G Thread
	200: Φ20mm	20: 3/4"			
	250: Φ25mm	25: 1"			

Ordering code of accessories

[Note] The wire length is 0.5m.

Ordering code of accessories is the same as 2S series valve's, Please refer to P184 for details of ordering code.

[Note] 320\400\500 series valves do not have mounting accessories.



Fluid control valve(2/2way)

2W Series (Internally piloted and normally closed)

Flow chart

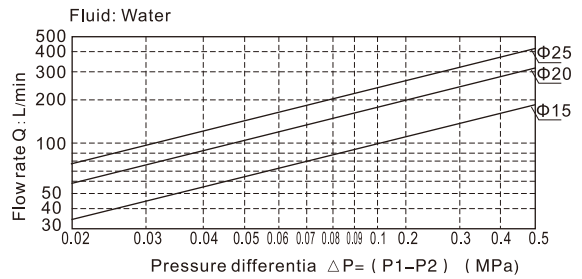
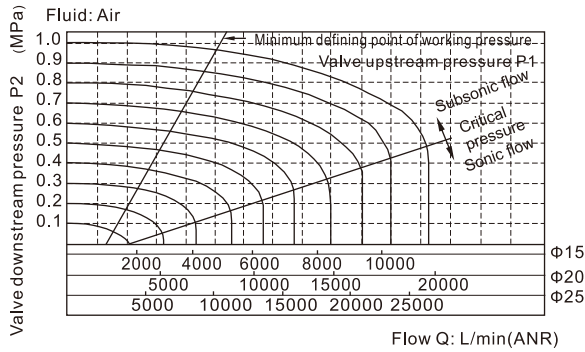

Dimensions

Terminal

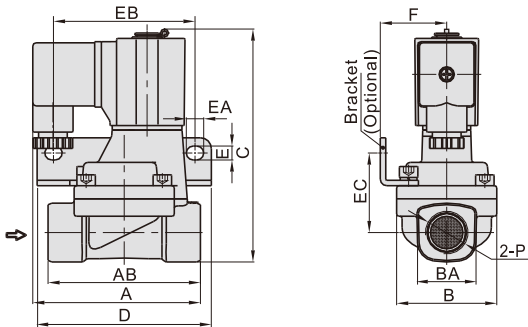

Model\Item	A	AB	B	BA	C	D	E	EA	EB	EC	F	P
2W150-15	77	70	46	27.5	107	80	6.4	8	65	36.5	30.5	1/2"
2W200-20	78.5	82	53	33.5	115.5	90	6.4	8	75	40	34	3/4"
2W250-25	81	92	59	40.5	124	95	6.4	8	80	44.5	36	1"

Grommet

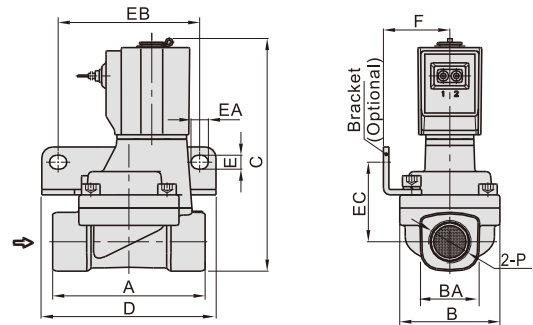

Model\Item	A	B	BA	C	D	E	EA	EB	EC	F	P
2W150-15	70	46	27.5	107	80	6.4	8	65	36.5	30.5	1/2"
2W200-20	82	53	33.5	115.5	90	6.4	8	75	40	34	3/4"
2W250-25	92	59	40.5	124	95	6.4	8	80	44.5	36	1"