

Preparation unit—Accessories

DPS Series digital display pressure sensor



Symbol



User interface Instruction

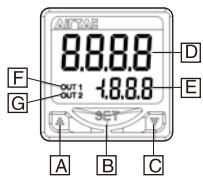

No.	Item
A	Value up button
B	Setting button
C	Value Down button
D	Pressure display area
E	Set pressure display area
F	Output 1 indicator light
G	Output 2 indicator light
H	Power and signal connector
J	Pressure input

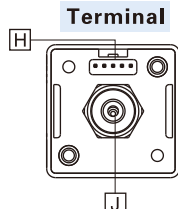

Terminal

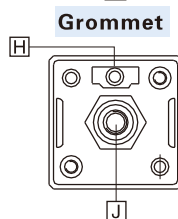

Grommet

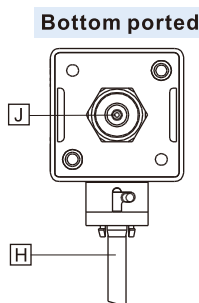

Bottom ported

Specification

Input power	Voltage	12~24 VDC ± 10% Ripple(p-p) < 10%	
Pressure range	Fluid	Non-corrosive gas	
	Measurement range	DPSN1(P1)-01: -100kPa~100kPa	
		DPSN1(P1)-10: -100kPa~1,000kPa	
	Withstand pressure	DPSN1(P1)-01: 200kPa	
		DPSN1(P1)-10: 1500kPa	
	Measurement error	± 2% F.S. , ± 1 digit(Temperature:25 ± 3°C)	
	Repetitive accuracy	± 0.2% F.S.	
Temperature error	± 3% F.S.(Base 25°C, Range 0 to 50°C)		
Display	Type	Double row LCD display,4-digit measurement, 3.5-digit setting	
	Color	2-color LCD (Red/Green)	
	Display period	100ms、250ms、500ms、1,000ms	
Output	Output group	DPSN1:Built-in two sets of NPN output DPSN1:Built-in two sets of PNP output	
	Transistor output	NPN:Maximum applied voltage 30V/100mA,Retained voltage <1.5V	
		PNP:Maximum applied voltage 30V/100mA,Retained voltage <1.5V	
	Output delay time	2ms、20ms、50ms、100ms、250ms、500ms 1,000ms、2,500ms、5,000ms	
	Hysteresis	DPSN1(P1)-01: 0.1、0.2、0.3..... 0.8(kPa) DPSN1(P1)-10: 1、2、3..... 8(kPa)	
Pressure Unit	Output mode	Basic mode, Hysteresis mode, Window comparator mode	
	DPSN1(P1)-01	kPa、kgf/cm ² 、bar、psi、mmHg、inHg	
	DPSN1(P1)-10	MPa、kPa、kgf/cm ² 、bar、psi、cmHg、inHg	
Vibration resistance		10 to 500Hz with 10mm Amplitude in X, Y, Z directions for 2hrs	
Impact resistance		Maximum 100m/s ² , X, Y, Z directions 3 times each	
Operating Temp. range		0~50°C	
Stored Temp. range		-20~65°C	
Humidity range		35%~80% RH(No condensation)	

Ordering code

DPS N1 □ -01 020 G

① ② ③ ④ ⑤ ⑥

① Model	② Output type	③ Electrical entry	④ Measurement range	⑤ Lead wire length	⑥ Piping specifications
DPS: Digital Display Pressure Sensor	N1: NPN P1: PNP	Space: Plug-in connector B: Pre-wired type [Note1] D: Bottom plug-in connector	01: -100kPa~100kPa 10: -100kPa~1,000kPa	020: Length 2m 030: Length 3m 050: Length 5m M08:300mm with M8 plug connector[Note2]	G: Male thread G1/8; female thread: M5

[Note1] The safety grade of pre-wired type is IP63.

[Note2] There is no plug-in connector type for M08.

The sockets of M08 need additional order. Please check on the right.

Ordering code of Socket F - EC M08 D 020



Category code	F: Accessory
Type code	EC: Connecting wire
Socket type	M08:M8 socket
Wire type	D: 4-wire type
Wire length	020: 2 meters 030:3meters 050:5meters 100:10meters

DPS Series digital display pressure sensor

Dimensions

Plug-in connector

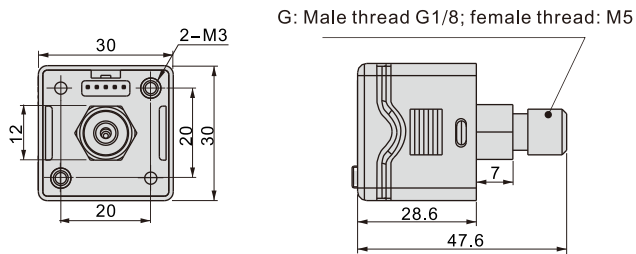

Pre-wired type

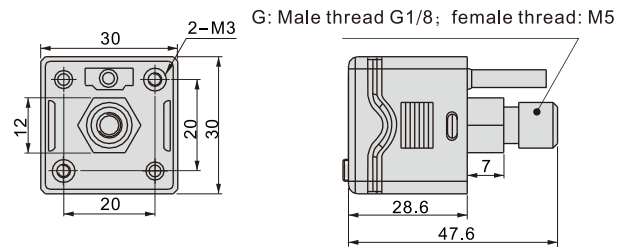

Bottom ported

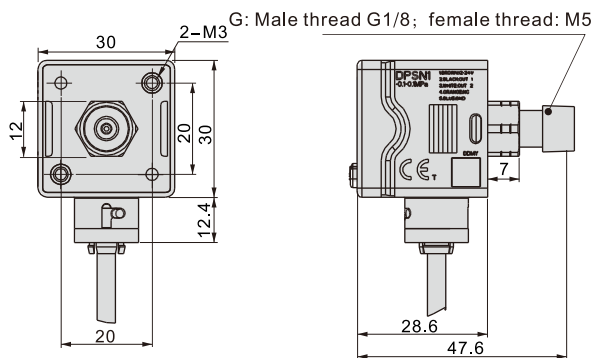

Dimensions/Assembly Instruction

Panel mount adapter + Front protective cover

Order the Installation accessories
(Ordering code: F-DPSEB, applicable to terminal and grommet type)

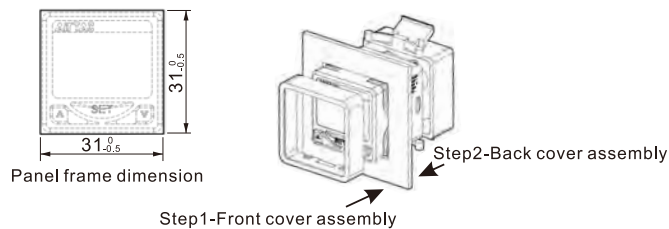

Order the installation accessories
(Ordering code: F-DPSDEB, applicable to bottom ported type)

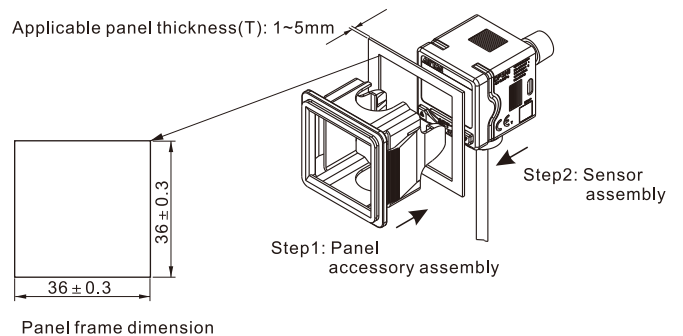

Bracket

Order the Installation accessories (Ordering code: F-DPSLB)

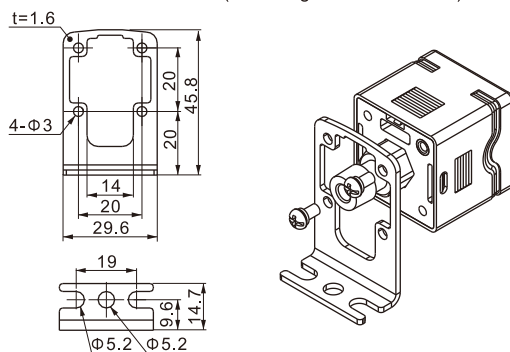

DPS Series digital display pressure sensor

User Interface Instructions

1. Mode switch

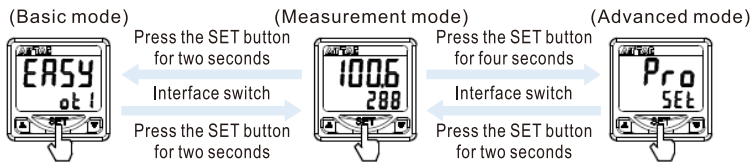

2. Basic mode

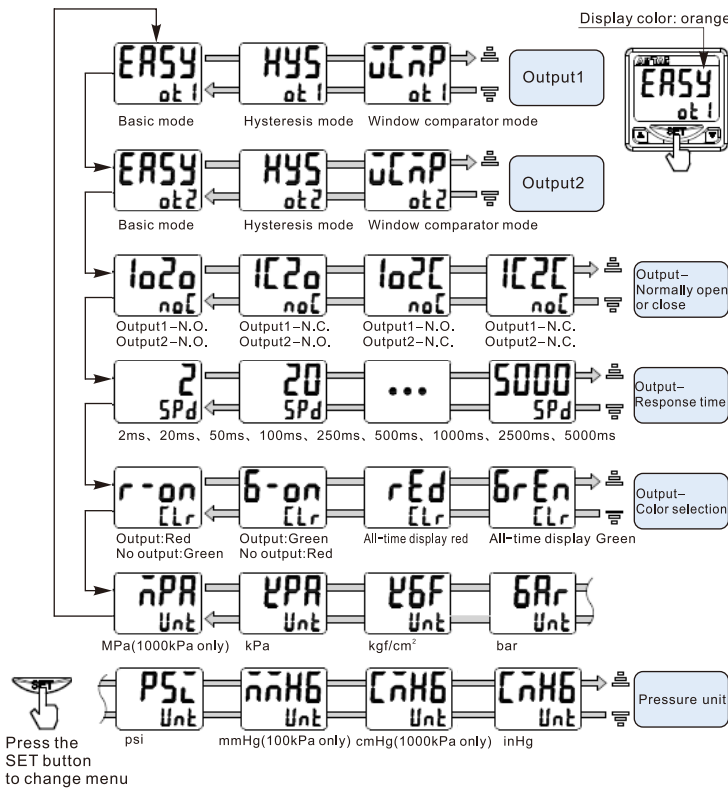

3. Base mode pressure setting

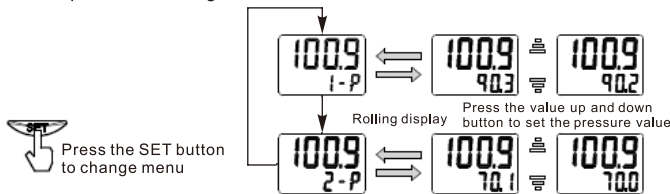

4. Hysteresis /window comparator mode

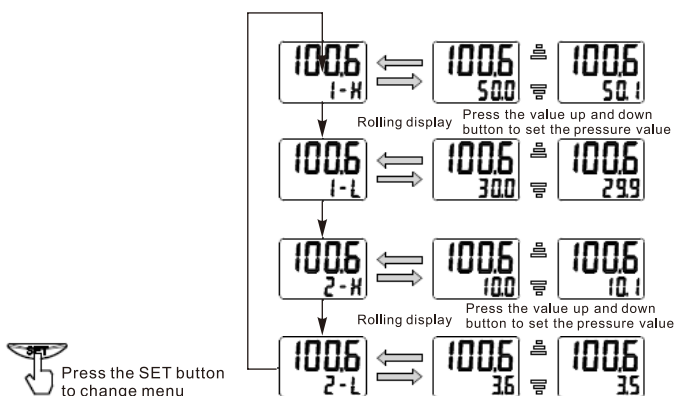

5. Interface of advanced mode

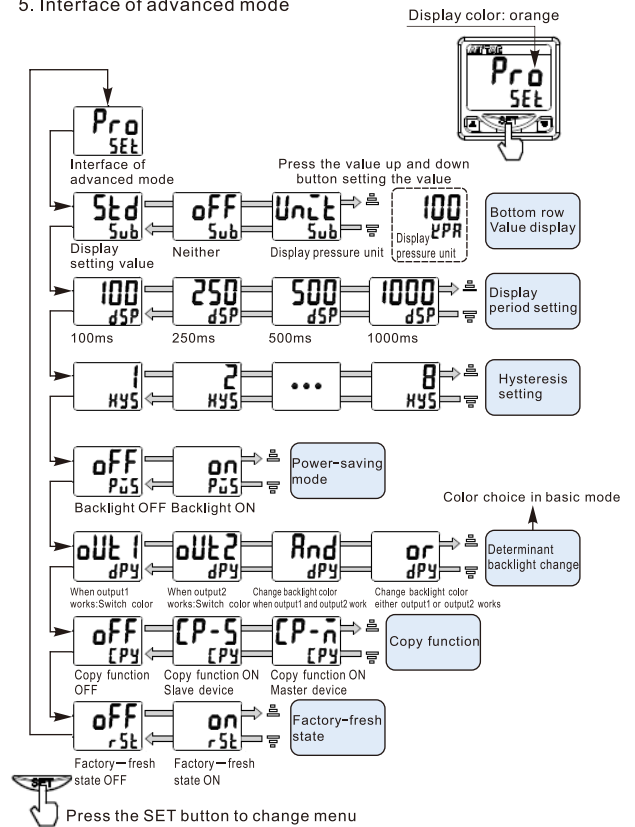

6. Copy function

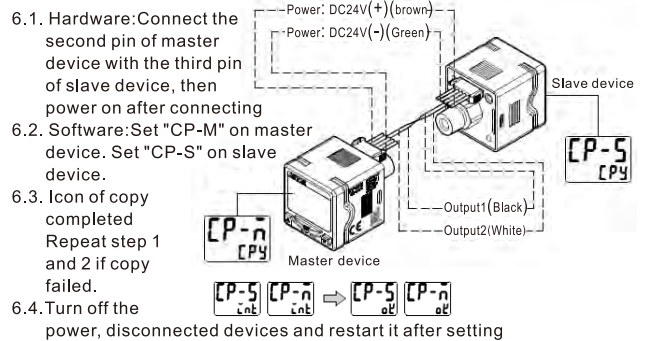

7. Zero-Clear Function

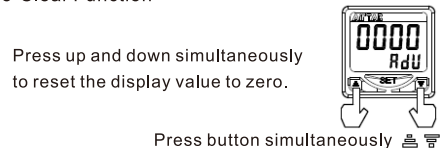

8. Key lock Function

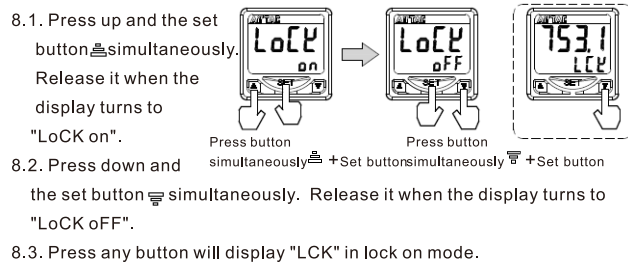

DPS Series digital display pressure sensor

Output mode

- 1. Basic mode:** Air pressure setting value 'P'. When air pressure large then (Setting value P+Hysteresis value), the output is 'NO'; When air pressure less than setting value 'P', the output is 'OFF'.

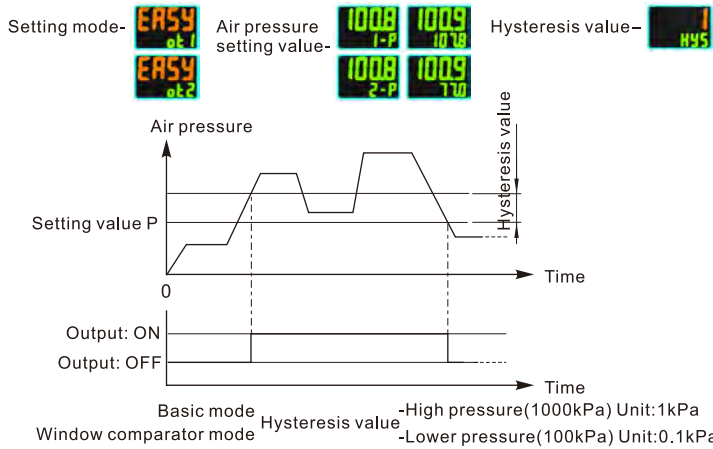

- 2. Hysteresis mode:** Air pressure setting value 'H/L'. When air pressure large then setting value 'H', the output is 'NO'; When air pressure less than setting value 'L', the output is 'OFF'.

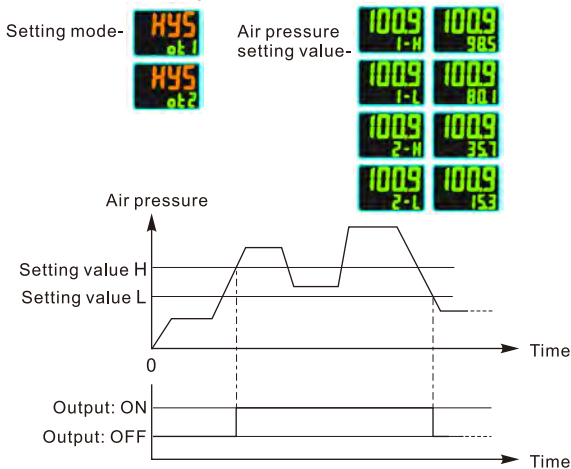

- 3. Window comparator mode:** Air pressure setting value 'H/L'. When air pressure large then value 'H' or less then value 'L', the output is 'OFF'; When air pressure large then value 'L' and less than value 'H', the output is 'ON'.

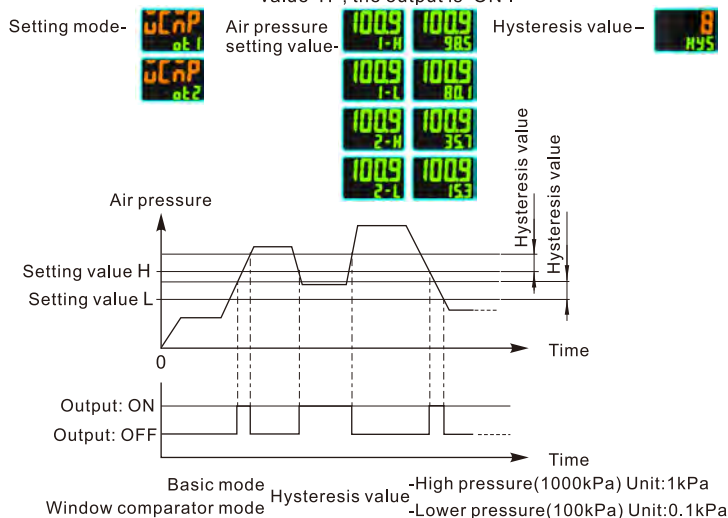

Connection Example

NPN Output

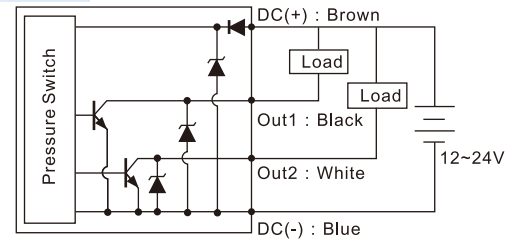

PNP Output

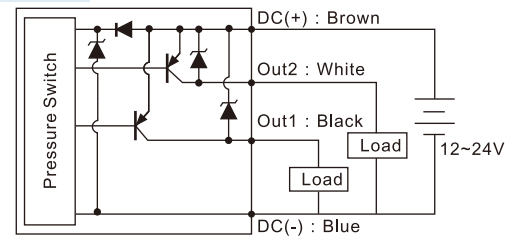

Notes

- Do not drop - knock or apply excessive impact while handling. Otherwise could cause damage and a malfunction.
- The tensile strength of the cord is 60N. Applying a greater pulling force on it can cause a malfunction.
- Do not exceed the screw-in torque of 7N.m when installing piping. Exceeding this value may cause malfunctioning of the sensor.
- Do not use it with corrosive and/or flammable gases or liquids.
- Please use it within rated pressure range.
- Turn off the power before connecting the wires.
- Don't use in an environment with spattering liquid of oil or solvent.
- Separate power lines from high voltage lines, avoiding wiring in the same conduit with these lines.
- When output current exceeds 100mA, circuit protection will be activated. System will resume once reboot.
- Adjust output-response response time can avoid errors caused by sudden change of working pressure.
- There is no copy function for PNP type.