



# Compact cylinder—ACQ Series

## Compendium of ACQ Series

**In accordance with JIS standard**

**Magnetic switch slots around the cylinder body**  
There are magnetic switch slots around the cylinder body convenient to install inducting switch.

**Two kinds of rod type**

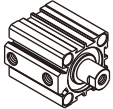

Female thread

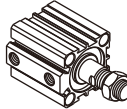

Male thread

**Multi-mounting accessories**

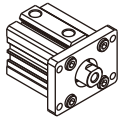

FA Type

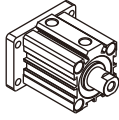

FB Type

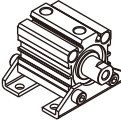



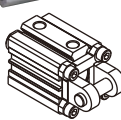



LB Type



CB Type

**Thirteen bore size are available**  
Bore size: 12, 16, 20, 25, 32, 40, 50, 63, 80, 100, 125, 140, 160

**Multi-type cylinder**

|  |   |
|--|---|
| ACQ: Compact cylinder (Double acting)              |  |
| ASQ: Compact cylinder (Single acting-push)         |  |
| ATQ: Compact cylinder (Single acting-pull)         |  |
| ACQD: Compact cylinder (Double rod)                |  |
| ACQJ: Compact cylinder (Adjustable stroke)         |  |
| TACQ: Compact cylinder (Double acting with guider) |  |

**Compact structure**  
C clip is adopted to connect the cylinder body and back cover or front cover, and riveted structure is adopted to connect piston and piston rod to make it compact and reliable.

### Criteria for selection: Cylinder thrust

|               |           | Unit: Newton(N) |                                 |                         |        |        |         |         |         |               |               |          |             |                                 |                         |           |         |        |         |         |        |        |         |
|---------------|-----------|-----------------|---------------------------------|-------------------------|--------|--------|---------|---------|---------|---------------|---------------|----------|-------------|---------------------------------|-------------------------|-----------|---------|--------|---------|---------|--------|--------|---------|
| Bore size     | Rod size  | Acting type     | Pressure area(mm <sup>2</sup> ) | Operating pressure(MPa) |        |        |         |         |         |               | Bore size     | Rod size | Acting type | Pressure area(mm <sup>2</sup> ) | Operating pressure(MPa) |           |         |        |         |         |        |        |         |
|               |           |                 |                                 | 0.1                     | 0.2    | 0.3    | 0.4     | 0.5     | 0.6     | 0.7           |               |          |             |                                 | 0.1                     | 0.2       | 0.3     | 0.4    | 0.5     | 0.6     | 0.7    |        |         |
| 12            | 6         | Single acting   | Push side                       | 113.1                   | -      | 13.6   | 24.9    | 36.2    | 47.5    | 58.9          | 70.2          | 40       | 16          | Single acting                   | Push side               | 1256.6    | 44.7    | 170.3  | 296.0   | 421.7   | 547.3  | 673.0  | 798.6   |
|               |           |                 | Pull side                       | 84.8                    | -      | 8.0    | 16.4    | 24.9    | 33.4    | 41.9          | 50.4          |          |             |                                 | Double acting           | Push side | 1055.6  | 24.6   | 130.1   | 235.7   | 341.2  | 446.8  | 552.3   |
|               |           | Push side       | 113.1                           | 11.3                    | 22.6   | 33.9   | 45.2    | 56.5    | 67.9    | 79.2          | Double acting |          |             | Push side                       |                         | 1256.6    | 125.7   | 251.3  | 377.0   | 502.7   | 628.3  | 754.0  | 879.6   |
|               |           | Pull side       | 84.8                            | 8.5                     | 17.0   | 25.4   | 33.9    | 42.4    | 50.9    | 59.4          |               |          |             | Single acting                   | Push side               | 1055.6    | 105.6   | 211.1  | 316.7   | 422.2   | 527.8  | 633.3  | 738.9   |
| 16            | 8         | Single acting   | Push side                       | 201.1                   | -      | 27.0   | 47.1    | 67.2    | 87.3    | 107.4         | 127.5         | 50       | 20          |                                 | Single acting           | Push side | 1963.5  | 96.3   | 292.7   | 489.0   | 685.4  | 881.7  | 1078.1  |
|               |           |                 | Pull side                       | 150.8                   | -      | 17.0   | 32.0    | 47.1    | 62.2    | 77.3          | 92.4          |          |             | Double acting                   |                         | Push side | 1649.3  | 64.9   | 229.9   | 394.8   | 559.7  | 724.7  | 889.6   |
|               |           | Push side       | 201.1                           | 20.1                    | 40.2   | 60.3   | 80.4    | 100.5   | 120.6   | 140.7         | Double acting |          |             |                                 | Push side               | 1963.5    | 196.3   | 392.7  | 589.0   | 785.4   | 981.7  | 1178.1 | 1374.4  |
|               |           | Pull side       | 150.8                           | 15.1                    | 30.2   | 45.2   | 60.3    | 75.4    | 90.5    | 105.6         |               |          |             | Single acting                   | Push side               | 1649.3    | 164.9   | 329.9  | 494.8   | 659.7   | 824.7  | 989.6  | 1154.5  |
| 20            | 10        | Single acting   | Push side                       | 314.2                   | -      | 36.8   | 68.2    | 99.7    | 131.1   | 162.5         | 193.9         | 63       | 20          |                                 | Single acting           | Push side | 3117.2  | 141.7  | 453.4   | 765.2   | 1076.9 | 1388.6 | 1700.3  |
|               |           |                 | Pull side                       | 235.6                   | -      | 21.1   | 44.7    | 68.2    | 91.8    | 115.4         | 138.9         |          |             | Double acting                   |                         | Push side | 2803.1  | 110.3  | 390.6   | 670.9   | 951.2  | 1231.5 | 1511.9  |
|               |           | Push side       | 314.2                           | 31.4                    | 62.8   | 94.2   | 125.7   | 157.1   | 188.5   | 219.9         | Double acting |          |             |                                 | Push side               | 3117.2    | 311.7   | 623.4  | 935.2   | 1246.9  | 1558.6 | 1870.3 | 2182.1  |
|               |           | Pull side       | 235.6                           | 23.6                    | 47.1   | 70.7   | 94.2    | 117.8   | 141.4   | 164.9         |               |          |             | Single acting                   | Push side               | 2803.1    | 280.3   | 560.6  | 840.9   | 1121.2  | 1401.5 | 1681.9 | 1962.2  |
| 25            | 12        | Single acting   | Push side                       | 490.9                   | 18.1   | 67.2   | 116.3   | 165.3   | 214.4   | 263.5         | 312.6         | 80       | 25          |                                 | Double acting           | Push side | 5026.5  | 502.7  | 1005.3  | 1508.0  | 2010.6 | 2513.3 | 3015.9  |
|               |           |                 | Pull side                       | 377.8                   | 6.8    | 44.6   | 82.3    | 120.1   | 157.9   | 195.7         | 233.4         |          |             | Double acting                   |                         | Push side | 4535.7  | 453.6  | 907.1   | 1360.7  | 1814.3 | 2267.8 | 2721.4  |
|               |           | Push side       | 490.9                           | 49.1                    | 98.2   | 147.3  | 196.3   | 245.4   | 294.5   | 343.6         | Double acting |          |             |                                 | Push side               | 7854.0    | 785.4   | 1570.8 | 2356.2  | 3141.6  | 3927.0 | 4712.4 | 5497.8  |
|               |           | Pull side       | 377.8                           | 37.8                    | 75.6   | 113.3  | 151.1   | 188.9   | 226.7   | 264.4         |               |          |             | Single acting                   | Push side               | 7049.7    | 705.0   | 1409.9 | 2114.9  | 2819.9  | 3524.9 | 4229.8 | 4934.8  |
| 32            | 16        | Single acting   | Push side                       | 804.2                   | 27.4   | 107.8  | 188.3   | 268.7   | 349.1   | 429.5         | 510.0         | 100      | 32          |                                 | Double acting           | Push side | 12271.8 | 1227.2 | 2454.4  | 3681.5  | 4908.7 | 6135.9 | 7363.1  |
|               |           |                 | Pull side                       | 603.2                   | 7.3    | 67.6   | 128.0   | 188.3   | 248.6   | 308.9         | 369.2         |          |             | Double acting                   |                         | Push side | 11467.6 | 1146.8 | 2293.5  | 3440.3  | 4587.0 | 5733.8 | 6880.6  |
|               |           | Push side       | 804.2                           | 80.4                    | 160.8  | 241.3  | 321.7   | 402.1   | 482.5   | 563.0         | Double acting |          |             |                                 | Push side               | 15393.8   | 1539.4  | 3078.8 | 4618.1  | 6157.5  | 7696.9 | 9236.3 | 10775.7 |
|               |           | Pull side       | 603.2                           | 60.3                    | 120.6  | 181.0  | 241.3   | 301.6   | 361.9   | 422.2         |               |          |             | Single acting                   | Push side               | 14589.6   | 1459.0  | 2917.9 | 4376.9  | 5835.8  | 7294.8 | 8753.8 | 10212.7 |
| Double acting | Push side | 20106.2         | 2010.6                          | 4021.2                  | 6031.9 | 8042.5 | 10053.1 | 12063.7 | 14074.3 | Double acting | Push side     | 18849.6  | 1885.0      |                                 | 3769.9                  | 5654.9    | 7539.8  | 9424.8 | 11309.8 | 13194.7 |        |        |         |
|               | Pull side | 603.2           | 60.3                            | 120.6                   | 181.0  | 241.3  | 301.6   | 361.9   | 422.2   |               |               |          |             |                                 |                         |           |         |        |         |         |        |        |         |

### Installation and application



- When load changes in the work, the cylinder with abundant output capacity shall be selected.
- Relative cylinder with high temperature resistance or corrosion resistance shall be chosen under the condition of high temperature or corrosion.
- Necessary protection measure shall be taken in the environment with higher humidity, much dust or water drops, oil dust and welding dregs.
- Dirty substances in the pipe must be eliminated before cylinder is connected with pipeline to prevent the entrance of particles into the cylinder.
- The medium used by cylinder shall be filtered to 40µm or below.
- As both of the front cover and piston of the cylinder are short, typically too large stroke can not be selected.
- Anti-freezing measure shall be adopted under low temperature environment to prevent moisture freezing.
- The cylinder shall avoid the influence of side load in operation to maintain the normal work of cylinder and extend the service life.
- If the cylinder is dismantled and stored for a long time, please conduct anti-rust treatment to the surface. Anti-dust caps shall be added in air inlet and outlet ports. The front and back cover can not be dismantled, which shall be especially noticed.
- C clip Installation:
  - Removal & Installation of C clip must be done with proper tool & care.
  - Ensure C clip is securely fitted into the proper slot to prevent leakage.



# Compact cylinder

## ACQ Series



### Specification

| Bore size(mm)      |               | 12  | 16 | 20 | 25   | 32 | 40 | 50   | 63 | 80   | 100 |
|--------------------|---------------|---|----|----|------|----|----|------|----|------|-----|
| Acting type        |               | Double acting   |    |    |      |    |    |      |    |      |     |
|                    |               | Single acting_Push type、Single acting_Pull type                                 |    |    |      |    |    |      |    |      |     |
| Fluid              |               | Air(to be filtered by 40μm filter element)                                      |    |    |      |    |    |      |    |      |     |
| Operating pressure | Double acting | 0.15~1.0MPa(22~145psi)  |    |    |      |    |    |      |    |      |     |
|                    | Single acting | 0.2~1.0MPa(28~145psi)   |    |    |      |    |    |      |    |      |     |
| Proof pressure     |               | 1.5MPa(215psi)  |    |    |      |    |    |      |    |      |     |
| Temperature °C     |               | -20~70  |    |    |      |    |    |      |    |      |     |
| Speed range mm/s   |               | Double acting: 30~500 Single acting: 50~500                                     |    |    |      |    |    |      |    |      |     |
| Stroke tolerance   |               | Stroke≤100 <sup>+1.0</sup> <sub>0</sub> Stroke>100 <sup>+1.5</sup> <sub>0</sub> |    |    |      |    |    |      |    |      |     |
| Cushion type       |               | Bumper  |    |    |      |    |    |      |    |      |     |
| Port size [Note1]  |               | M5×0.8  |    |    | 1/8" |    |    | 1/4" |    | 3/8" |     |

[Note1] G thread is available.  
Add) Refer to P568 for detail of sensor switch.

### Symbol

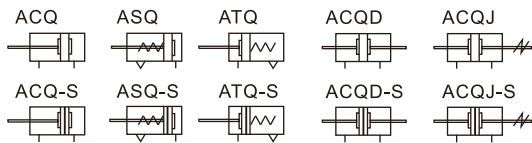

### Product feature

- JIS standard is implemented.
- C clip is adopted to connect the cylinder body and back cover or front cover, and riveted structure is adopted to connect piston and piston rod to make it compact and reliable.
- The internal diameter of the body is treated with rolling followed by the treatment of hard anodizing, forming an excellent abrasion resistance and durability.
- The seal of piston adopts heterogeneous two-way seal structure. It has compact dimension and the function of grease reservation.
- Compact structure can effectively save installation space.
- There are magnetic switch slots around the cylinder body, which is convenient to install inducting switch.
- Installing accessories with various specifications are optional.

### Stroke

| Bore size (mm) |               | Standard stroke (mm) |    |    |    |    |    |    |    |    | Max.std stroke |    |    |    |    |    |     |
|----------------|---------------|----------------------|----|----|----|----|----|----|----|----|----------------|----|----|----|----|----|-----|
|                |               | 5                    | 10 | 15 | 20 | 25 | 30 | 35 | 40 | 45 |                | 50 |    |    |    |    |     |
| 12             | Double acting | 5                    | 10 | 15 | 20 | 25 | 30 | 35 | 40 | 45 | 50             | 50 |    |    |    |    |     |
|                | Single acting | 5                    | 10 | 15 | 20 |    |    |    |    |    |                | 20 |    |    |    |    |     |
| 16             | Double acting | 5                    | 10 | 15 | 20 | 25 | 30 | 35 | 40 | 45 | 50             | 55 | 60 |    |    |    |     |
|                | Single acting | 5                    | 10 | 15 | 20 |    |    |    |    |    |                | 20 |    |    |    |    |     |
| 20             | Double acting | 5                    | 10 | 15 | 20 | 25 | 30 | 35 | 40 | 45 | 50             | 60 | 70 | 75 | 80 | 90 | 100 |
|                | Single acting | 5                    | 10 | 15 | 20 | 25 | 30 |    |    |    |                |    |    |    |    |    | 30  |
| 25             | Double acting | 5                    | 10 | 15 | 20 | 25 | 30 |    |    |    |                |    |    |    |    |    |     |
|                | Single acting | 5                    | 10 | 15 | 20 | 25 | 30 |    |    |    |                |    |    |    |    |    |     |
| 32             | Double acting | 5                    | 10 | 15 | 20 | 25 | 30 | 35 | 40 | 45 | 50             | 60 | 70 | 75 | 80 | 90 | 100 |
|                | Single acting | 5                    | 10 | 15 | 20 | 25 | 30 |    |    |    |                |    |    |    |    |    |     |
| 40             | Double acting | 5                    | 10 | 15 | 20 | 25 | 30 |    |    |    |                |    |    |    |    |    |     |
|                | Single acting | 5                    | 10 | 15 | 20 | 25 | 30 |    |    |    |                |    |    |    |    |    |     |
| 50             | Double acting | 5                    | 10 | 15 | 20 | 25 | 30 |    |    |    |                |    |    |    |    |    |     |
|                | Single acting | 5                    | 10 | 15 | 20 | 25 | 30 |    |    |    |                |    |    |    |    |    |     |
| 63             | Double acting | 5                    | 10 | 15 | 20 | 25 | 30 |    |    |    |                |    |    |    |    |    |     |
|                | Single acting | 5                    | 10 | 15 | 20 | 25 | 30 |    |    |    |                |    |    |    |    |    |     |
| 80             | Double acting | 5                    | 10 | 15 | 20 | 25 | 30 | 35 | 40 | 45 | 50             | 60 | 70 | 75 | 80 | 90 | 100 |
|                | Single acting | 5                    | 10 | 15 | 20 | 25 | 30 |    |    |    |                |    |    |    |    |    |     |
| 100            | Double acting | 5                    | 10 | 15 | 20 | 25 | 30 | 35 | 40 | 45 | 50             | 60 | 70 | 75 | 80 | 90 | 100 |
|                | Single acting | 5                    | 10 | 15 | 20 | 25 | 30 |    |    |    |                |    |    |    |    |    |     |

Note) 1. Please contact the company for other special strokes.  
2. The dimensions of non-std stroke cylinder has the same dimensions as the next longer stroke std. stroke cylinder. e.g. 23mm stroke cylinder has the same dimensions of 25 std. stroke cylinder.

### Ordering code

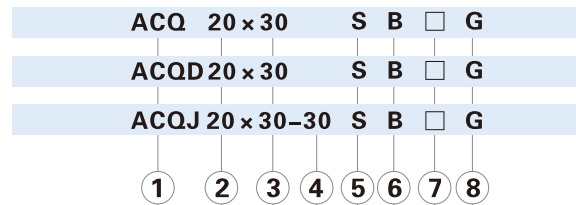

| ① Model                                    | ② Bore size                       | ③ Stroke                          | ④ Adjustable Stroke      | ⑤ Magnet                                | ⑥ Rod type                             | ⑦ Mounting type [Note1]   | ⑧ Thread type [Note2] |
|--|-----------------------------------|-----------------------------------|--------------------------|---|--|---|-----------------------|
| ACQ: Compact cylinder (Double acting)      | 12 16 20 25 32 40<br>50 63 80 100 | Refer to stroke table for details | No this code             | Blank: Without magnet<br>S: With magnet | Blank: Female thread<br>B: Male thread | Blank: No accessories<br>FA: FA type<br>FB: FB type<br>CB: CB type<br>LB: LB type | G: G Thread           |
| ASQ: Compact cylinder (Single acting-push) | 12 16 20 25<br>32 40 50 63        |                                   |                          |   |  |   |                       |
| ATQ: Compact cylinder (Single acting-pull) | 12 16 20 25<br>32 40 50 63        |                                   |                          |   |  |   |                       |
| ACQD: Compact cylinder (Double rod)        | 12 16 20 25<br>32 40 50 63        |                                   |                          |   |  |   |                       |
| ACQJ: Compact cylinder (Adjustable stroke) | 80 100                            |                                   |                          |   |  |   |                       |
|  |                                   |                                   | 10 20 30 40<br>50 75 100 |   |  | Blank: No accessories<br>FA: FA type<br>FB: FB type<br>LB: LB type                |                       |

[Note1] Please refer to page 347~348 for accessory parts.  
[Note2] Standard thread is blank here.

# Compact cylinder

## ACQ Series

### Inner structure and material of major parts

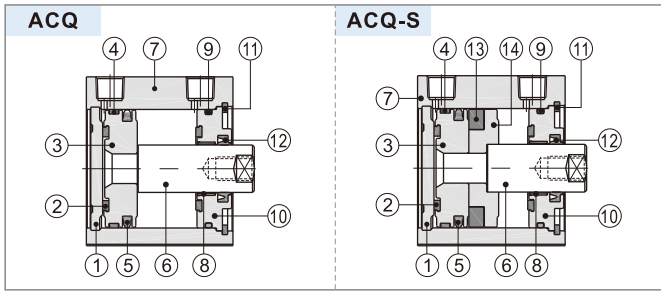

| NO. | Item                | Material  |
|-----|---------------------|---|
| 1   | Back cover          | No(Φ 12, 16)\Aluminum alloy(Others)                           |
| 2   | Bumper              | TPU(Φ 12~25)\NBR(Others)                                      |
| 3   | Piston              | Brass(Φ 12, 16)\Aluminum alloy(Others)                        |
| 4   | Wear ring           | No(Φ 12~32)\Wear resistant material(Others)                   |
| 5   | Piston seal         | NBR   |
| 6   | Piston rod          | Carbon steel with 20μm chrome plated                          |
| 7   | Body                | Aluminum alloy  |
| 8   | Bushing             | No(Φ 12~32)\Wear resistant material(Others)                   |
| 9   | O-ring              | NBR   |
| 10  | Front cover         | Aluminum alloy  |
| 11  | C clip              | Spring steel  |
| 12  | Front cover packing | NBR   |
| 13  | Magnet              | Sintered metal(Neodymium-iron-boron)(Φ 12~25)\Plastic(Others) |
| 14  | Magnet holder       | Brass(Φ 12, 16)\Aluminum alloy(Others)                        |

### Dimensions

**ACQ**  
Φ12, Φ16

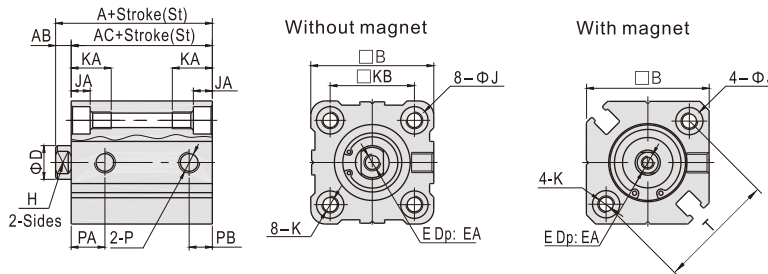

Φ20, Φ25

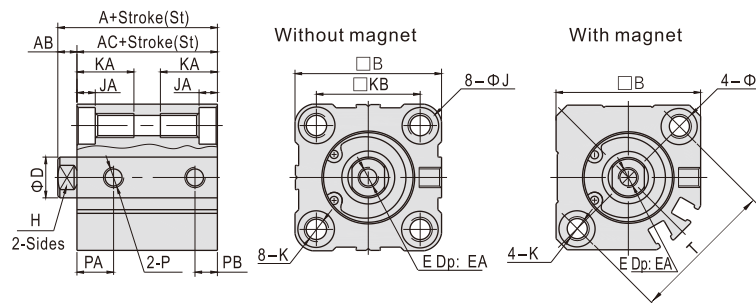

| Type | Without magnet |    |      |      |      |      | With magnet |      |     |    |    |        | Without magnet |    |   |     | With magnet           |    |      |        |     |     |     |     |    |
|------|----------------|----|------|------|------|------|-------------|------|-----|----|----|--------|----------------|----|---|-----|-----------------------|----|------|--------|-----|-----|-----|-----|----|
|      | A              |    | AC   |      | A    |      | AC          |      | AB  | B  | D  | E      | EA             | H  | J | JA  | K                     | KA | KB   | P      | PA  | PB  | PA  | PB  | T  |
| 12   | 20.5           | -  | -    | 17   | -    | -    | 31.5        | 28   | 3.5 | 25 | 6  | M3×0.5 | 6              | 5  | 6 | 3.5 | M4×0.7 Thru.hole:Φ3.4 | 11 | 15.5 | M5×0.8 | 7.5 | 5   | 9   | 7   | 22 |
| 16   | 22             | 22 | 22   | 18.5 | 18.5 | 18.5 | 34          | 30.5 | 3.5 | 29 | 8  | M4×0.7 | 8              | 6  | 6 | 3.5 | M4×0.7 Thru.hole:Φ3.4 | 11 | 20   | M5×0.8 | 8   | 5.5 | 9.5 | 5.5 | 28 |
| 20   | 24             | -  | 34   | 19.5 | -    | 29.5 | 36          | 31.5 | 4.5 | 36 | 10 | M5×0.8 | 7              | 8  | 9 | 5.5 | M6×1.0 Thru.hole:Φ5.2 | 17 | 25.5 | M5×0.8 | 9   | 5.5 | 9.5 | 5.5 | 36 |
| 25   | 27.5           | -  | 37.5 | 22.5 | -    | 32.5 | 37.5        | 32.5 | 5   | 40 | 12 | M6×1.0 | 12             | 10 | 9 | 5.5 | M6×1.0 Thru.hole:Φ5.2 | 17 | 28   | M5×0.8 | 11  | 5.5 | 11  | 5.5 | 40 |

Φ32-Φ100 (Strokes≤100)

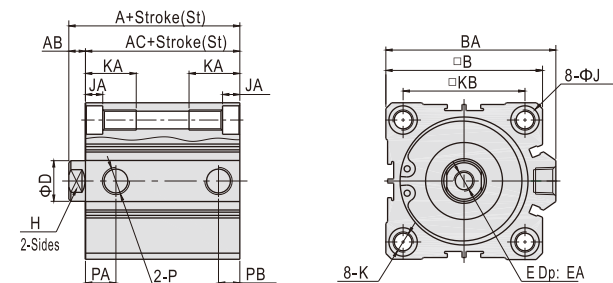

| Item | A(Without magnet) |       | A    | AB | AC(Without magnet) |       | AC   | B   | BA    | D  | E       |
|------|-------------------|-------|------|----|--------------------|-------|------|-----|-------|----|---------|
|      | St≤50             | St≥60 |      |    | (With magnet)      | St≤50 |      |     |       |    |         |
| 32   | 30                | 40    | 40   | 7  | 23                 | 33    | 33   | 45  | 49.5  | 16 | M8×1.25 |
| 40   | 36.5              | 46.5  | 46.5 | 7  | 29.5               | 39.5  | 39.5 | 53  | 57    | 16 | M8×1.25 |
| 50   | 38.5              | 48.5  | 48.5 | 8  | 30.5               | 40.5  | 40.5 | 64  | 71    | 20 | M10×1.5 |
| 63   | 44                | 54    | 54   | 8  | 36                 | 46    | 46   | 77  | 84    | 20 | M10×1.5 |
| 80   | 53.5              | 63.5  | 63.5 | 10 | 43.5               | 53.5  | 53.5 | 98  | 104   | 25 | M16×2.0 |
| 100  | 65                | 75    | 75   | 12 | 53                 | 63    | 63   | 117 | 123.5 | 32 | M20×2.5 |

| Item | Bore size | EA | H  | J    | JA  | K                        | KA Note | KB | P    | Without magnet |        | With magnet |      |
|------|-----------|----|----|------|-----|--------------------------|---------|----|------|----------------|--------|-------------|------|
|      |           |    |    |      |     |                          |         |    |      | PA             | PB     | PA          | PB   |
| 32   | St=5      | 13 | 14 | 9    | 5.5 | M6×1.0 Thru.hole:Φ5.2    | 17      | 34 | 1/8" | 7.5            | 6.5    | 10.5        | 7.5  |
|      | St>5      |    |    |      |     |                          |         |    |      | 10.5           | 7.5    |             |      |
| 40   |           | 13 | 14 | 9    | 5.5 | M6×1.0 Thru.hole:Φ5.2    | 17      | 40 | 1/8" | 11             | 8      | 11          | 8    |
| 50   | St=5      | 15 | 17 | 10.5 | 6.5 | M8×1.25 Thru.hole:Φ6.8   | 22      | 50 | 1/4" | 9              | 9      | 10.5        | 10.5 |
|      | St>5      |    |    |      |     |                          |         |    |      | 10.5           | 10.5   |             |      |
| 63   | St≥25     | 15 | 17 | 14   | 9   | M10×1.5 Thru.hole:Φ8.5   | 28.5    | 60 | 1/4" | 14             | 9.5    | 15          | 10.5 |
|      | St=20     |    |    |      |     |                          | 27      |    |      | (15)           | (10.5) |             |      |
|      | St≤15     |    |    |      |     |                          | thread  |    |      |                |        |             |      |
| 80   |           | 20 | 22 | 17   | 11  | M12×1.75 Thru.hole:Φ10.3 | 35.5    | 77 | 3/8" | 16             | 14     | 16          | 14   |
| 100  |           | 26 | 27 | 17   | 11  | M12×1.75 Thru.hole:Φ10.3 | 35.5    | 94 | 3/8" | 20             | 17.5   | 20          | 17.5 |

Note: PA/PB in "( )" is the value when stroke > 5.

Note) The dimensions of non-std stroke cylinder has the same dimensions as the next longer stroke std. stroke cylinder. e.g. 55mm stroke cylinder has the same dimensions of 60 std. stroke cylinder.



# Compact cylinder

## ACQ Series

### ASQ

Φ12、Φ16

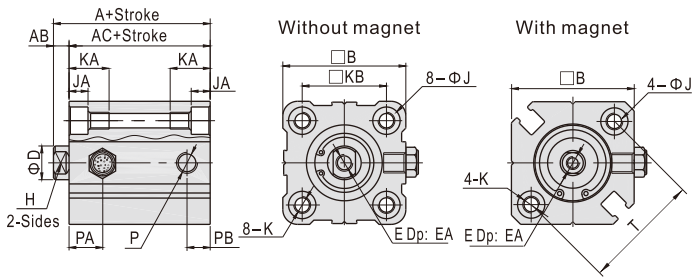

### ATQ

Φ12、Φ16

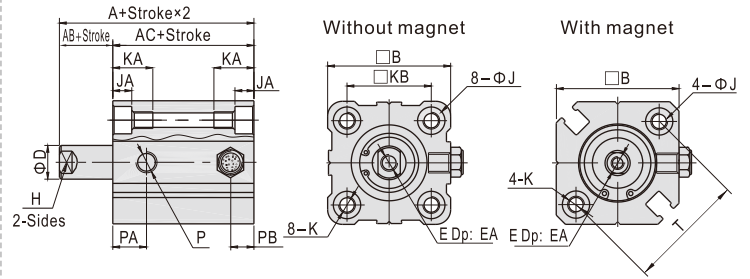

Φ20 Φ25

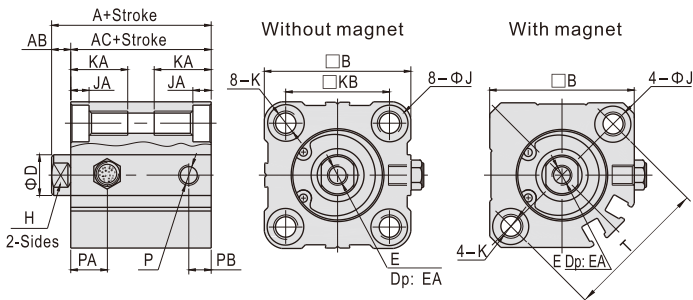

Φ20 Φ25

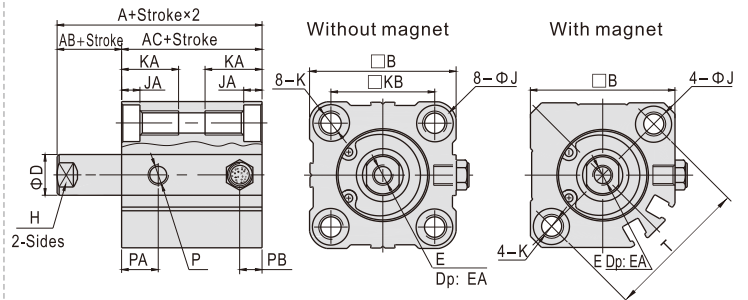

Φ32-Φ63

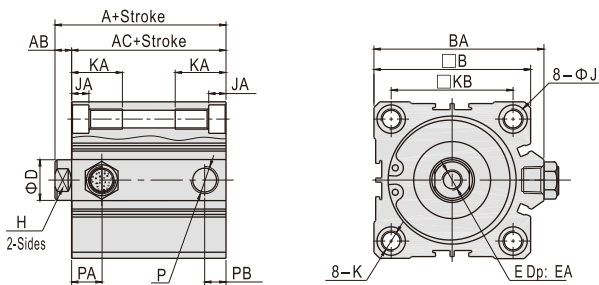

Φ32-Φ63

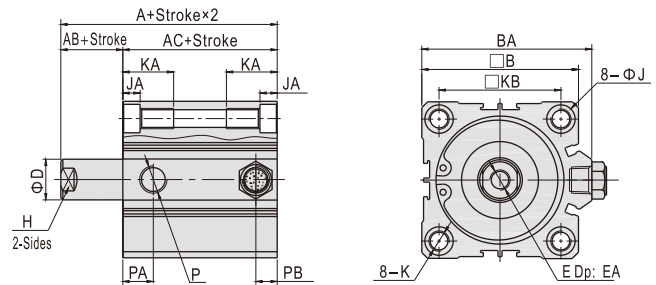

| Bore size\Item<br>Stroke | A(Without magnet) |       |       | A(With magnet) |       |       | AB  | AC(Without magnet) |       |       | AC(With magnet) |       |       | B  | BA   | D  | E       | EA |
|--------------------------|-------------------|-------|-------|----------------|-------|-------|-----|--------------------|-------|-------|-----------------|-------|-------|----|------|----|---------|----|
|                          | 5\10              | 15\20 | 25\30 | 5\10           | 15\20 | 25\30 |     | 5\10               | 15\20 | 25\30 | 5\10            | 15\20 | 25\30 |    |      |    |         |    |
| 12                       | 25.5              | 30.5  | -     | 36.5           | 41.5  | -     | 3.5 | 22                 | 27    | -     | 33              | 38    | -     | 25 | -    | 6  | M3×0.5  | 6  |
| 16                       | 27                | 32    | -     | 39             | 44    | -     | 3.5 | 23.5               | 28.5  | -     | 35.5            | 40.5  | -     | 29 | -    | 8  | M4×0.7  | 8  |
| 20                       | 29                | 34    | 39    | 41             | 46    | 51    | 4.5 | 24.5               | 29.5  | 34.5  | 36.5            | 41.5  | 46.5  | 36 | -    | 10 | M5×0.8  | 7  |
| 25                       | 32.5              | 37.5  | 42.5  | 42.5           | 47.5  | 52.5  | 5   | 27.5               | 32.5  | 37.5  | 37.5            | 42.5  | 47.5  | 40 | -    | 12 | M6×1.0  | 12 |
| 32                       | 35                | 40    | 45    | 45             | 50    | 55    | 7   | 28                 | 33    | 38    | 38              | 43    | 48    | 45 | 49.5 | 16 | M8×1.25 | 13 |
| 40                       | 41.5              | 46.5  | 51.5  | 51.5           | 56.5  | 61.5  | 7   | 34.5               | 39.5  | 44.5  | 44.5            | 49.5  | 54.5  | 53 | 57   | 16 | M8×1.25 | 13 |
| 50                       | 48.5              | 53.5  | 58.5  | 58.5           | 63.5  | 68.5  | 8   | 40.5               | 45.5  | 50.5  | 50.5            | 55.5  | 60.5  | 64 | 71   | 20 | M10×1.5 | 15 |
| 63                       | 54                | 59    | 64    | 64             | 69    | 74    | 8   | 46                 | 51    | 56    | 56              | 61    | 66    | 77 | 84   | 20 | M10×1.5 | 15 |

| Bore size\Item | H  | J    | JA  | K           |             | KA   | KB   | P      | PA(Without magnet) | PA(With magnet) | PB(Without magnet) | PB(With magnet) | T  |
|----------------|----|------|-----|-------------|-------------|------|------|--------|--------------------|-----------------|--------------------|-----------------|----|
|                |    |      |     | Thru.hole:Φ | Thru.hole:Φ |      |      |        |                    |                 |                    |                 |    |
| 12             | 5  | 6    | 3.5 | M4×0.7      | Φ3.4        | 11   | 15.5 | M5×0.8 | 7.5                | 9               | 5                  | 7               | 22 |
| 16             | 6  | 6    | 3.5 | M4×0.7      | Φ3.4        | 11   | 20   | M5×0.8 | 8                  | 9.5             | 5.5                | 5.5             | 28 |
| 20             | 8  | 9    | 5.5 | M6×1.0      | Φ5.2        | 17   | 25.5 | M5×0.8 | 9                  | 9.5             | 5.5                | 5.5             | 36 |
| 25             | 10 | 9    | 5.5 | M6×1.0      | Φ5.2        | 17   | 28   | M5×0.8 | 11                 | 11              | 5.5                | 5.5             | 40 |
| 32             | 14 | 9    | 5.5 | M6×1.0      | Φ5.2        | 17   | 34   | 1/8"   | 10.5               | 10.5            | 7.5                | 7.5             | -  |
| 40             | 14 | 9    | 5.5 | M6×1.0      | Φ5.2        | 17   | 40   | 1/8"   | 11                 | 11              | 8                  | 8               | -  |
| 50             | 17 | 10.5 | 6.5 | M8×1.25     | Φ6.8        | 22   | 50   | 1/4"   | 10.5               | 10.5            | 10.5               | 10.5            | -  |
| 63             | 17 | 14   | 9   | M10×1.5     | Φ8.5        | 28.5 | 60   | 1/4"   | 15                 | 15              | 10.5               | 10.5            | -  |

# Compact cylinder

## ACQ Series

### ACQD

φ12、φ16

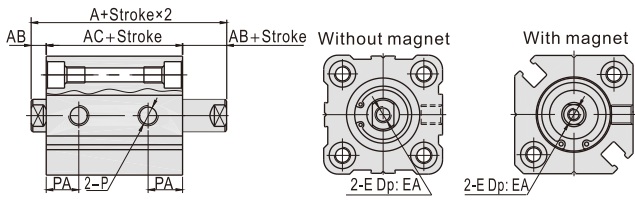

### ACQJ

φ12、φ16

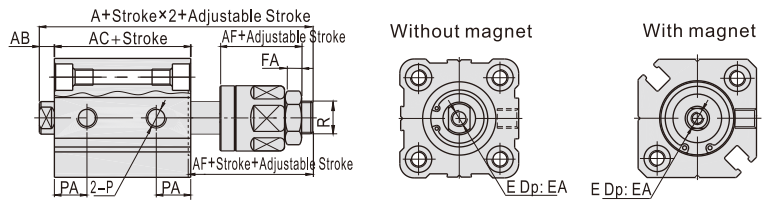

φ20 φ25

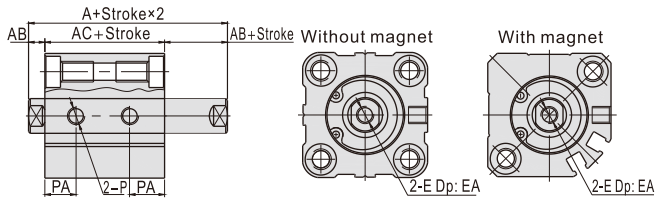

φ20 φ25

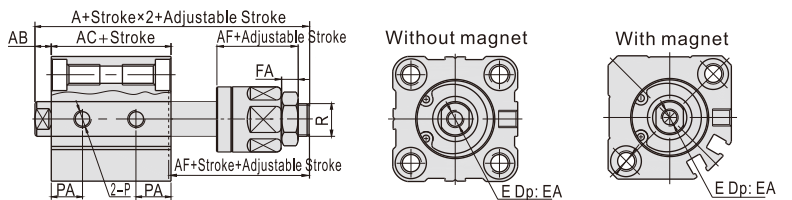

φ32~φ100

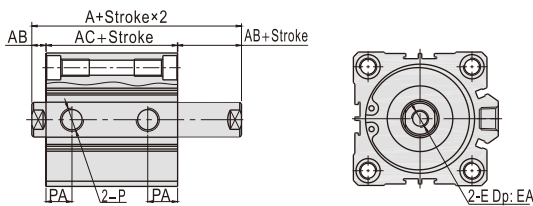

φ32~φ100

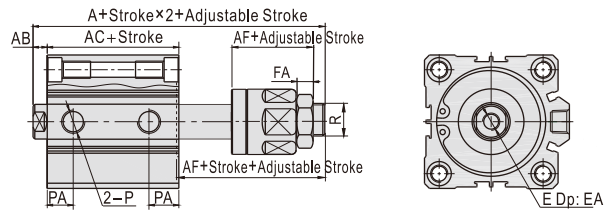

| Item | A(ACQD)        |             | A(ACQJ)        |             | AC(ACQD)       |             | AC(ACQJ)       |             | AB  | AF   | E       | EA                  | FA   | PA                  | R        |
|------|----------------|-------------|----------------|-------------|----------------|-------------|----------------|-------------|-----|------|---------|---------------------|------|---------------------|----------|
|      | Without magnet | With magnet | Without magnet | With magnet | Without magnet | With magnet | Without magnet | With magnet |     |      |         |                     |      |                     |          |
| 12   | 32.2           | 39.4        | 45.2           | 52.4        | 25.2           | 32.4        | 25.2           | 32.4        | 3.5 | 17   | M3×0.5  | 6                   | 4    | 9                   | M5×0.8   |
| 16   | 33             | 43          | 50             | 60          | 26             | 36          | 26             | 36          | 3.5 | 21   | M4×0.7  | 8                   | 5    | 9.5                 | M6×1.0   |
| 20   | 35             | 47          | 55             | 67          | 26             | 38          | 26             | 38          | 4.5 | 25   | M5×0.8  | 7                   | 6    | 9.5                 | M8×1.25  |
| 25   | 39             | 49          | 60.5           | 70.5        | 29             | 39          | 29             | 39          | 5   | 27   | M6×1.0  | 9.5(St≤5)/12(St>5)  | 6    | 11                  | M10×1.25 |
| 32   | 44.5           | 54.5        | 64.9           | 74.9        | 30.5           | 40.5        | 30.5           | 40.5        | 7   | 28   | M8×1.25 | 9(St≤10)/13(St>10)  | 7    | 10                  | M12×1.25 |
| 40   | 54             | 64          | 74.5           | 84.5        | 40             | 50          | 40             | 50          | 7   | 28   | M8×1.25 | 11(St≤10)/13(St>10) | 7    | 13                  | M12×1.25 |
| 50   | 56.5           | 66.5        | 77             | 87          | 40.5           | 50.5        | 40.5           | 50.5        | 8   | 29   | M10×1.5 | 12(St≤10)/15(St>10) | 8    | 13.5                | M16×1.5  |
| 63   | 58             | 68          | 78.4           | 88.4        | 42             | 52          | 42             | 52          | 8   | 29   | M10×1.5 | 12(St≤10)/15(St>10) | 8    | 14.5(St=5)/16(St>5) | M16×1.5  |
| 80   | 71             | 81          | 95.8           | 105.8       | 51             | 61          | 51             | 61          | 10  | 35.5 | M16×2.0 | 14(St≤15)/20(St>15) | 10   | 16                  | M20×1.5  |
| 100  | 84.5           | 94.5        | 114.3          | 124.3       | 60.5           | 70.5        | 60.5           | 70.5        | 12  | 42.5 | M20×2.5 | 20(St≤25)/26(St>25) | 13.5 | 21                  | M27×2.0  |

Remark) The unmarked dimension is the same as ACQ standard type. Please refer to this page for male thread dimensions.

### Male thread

(Bore size: φ12~φ100, Stroke≤100)

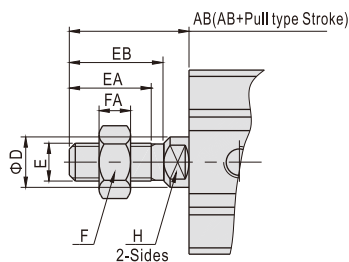

| Bore size/Item | AB   | D  | E        | EA   | EB   | F  | FA | H  |
|----------------|------|----|----------|------|------|----|----|----|
| 12             | 14   | 6  | M5×0.8   | 9    | 10   | 8  | 4  | 5  |
| 16             | 15.5 | 8  | M6×1.0   | 10   | 11.5 | 10 | 5  | 6  |
| 20             | 18.5 | 10 | M8×1.25  | 12   | 13.5 | 12 | 6  | 8  |
| 25             | 22.5 | 12 | M10×1.25 | 15   | 17   | 17 | 6  | 10 |
| 32             | 28.5 | 16 | M14×1.5  | 20.5 | 23.5 | 19 | 8  | 14 |
| 40             | 28.5 | 16 | M14×1.5  | 20.5 | 23.5 | 19 | 8  | 14 |
| 50             | 34   | 20 | M18×1.5  | 25.5 | 27.5 | 27 | 11 | 17 |
| 63             | 33.5 | 20 | M18×1.5  | 26   | 28   | 27 | 11 | 17 |
| 80             | 43.5 | 25 | M22×1.5  | 32.5 | 35.5 | 32 | 13 | 22 |
| 100            | 43.5 | 32 | M26×1.5  | 32.5 | 35.5 | 36 | 13 | 27 |

# Compact cylinder

ACQ Series——Big bore size



## Specification

| Bore size(mm)      | 125  | 140 | 160 |
|--------------------|--|-----|-----|
| Acting type        | Double acting                              |     |     |
| Fluid              | Air(to be filtered by 40μm filter element) |     |     |
| Operating pressure | 0.15~1.0MPa(22~145psi)                     |     |     |
| Proof pressure     | 1.5MPa(215psi)                             |     |     |
| Temperature °C     | -20~70                                     |     |     |
| Speed range mm/s   | 30~500                                     |     |     |
| Stroke tolerance   | Stroke≤100 $+1.0_0$ Stroke>100 $+1.5_0$    |     |     |
| Cushion type       | Bumper                                     |     |     |
| Port size [Note1]  | 3/8"                                       |     |     |

[Note1] G thread is available.  
Add) Refer to P568 for detail of sensor switch.

## Symbol



## Product feature

1. JIS standard is implemented.
2. C clip is adopted to connect the cylinder body and back cover or front cover to make it compact and reliable.
3. The internal diameter of the body is treated with rolling followed by the treatment of hard anodizing, forming an excellent abrasion resistance and durability.
4. The seal of piston adopts heterogeneous two-way seal structure. It has compact dimension and the function of grease reservation.
5. Compact structure can effectively save installation space.
6. There are magnetic switch slots around the cylinder body, which is convenient to install inducting switch.

## Stroke

| Bore size (mm) | Standard stroke (mm)                          | Max.std stroke |
|----------------|---|----------------|
| 125            | 10 20 30 40 50 75 100 125 150 175 200 250 300 | 300            |
| 140            |   |                |
| 160            |   |                |

Note) Please contact us for special strokes.

## Ordering code

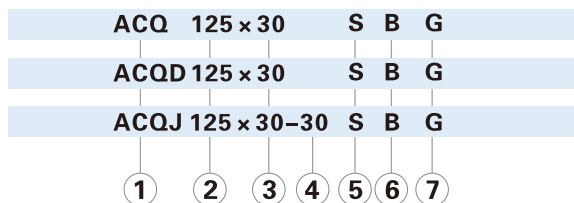

| ① Model                                    | ② Bore size | ③ Stroke                          | ④ Adjustable Stroke      | ⑤ Magnet       | ⑥ Rod type                             | ⑦ Thread type |
|--|-------------|-----------------------------------|--------------------------|----------------|--|---------------|
| ACQ: Compact cylinder (Double acting)      | 125 140 160 | Refer to stroke table for details | No this code             | S: With magnet | Blank: Female thread<br>B: Male thread | G: G Thread   |
| ACQD: Compact cylinder (Double rod)        |             |                                   |                          |                |  |               |
| ACQJ: Compact cylinder (Adjustable stroke) |             |                                   | 10 20 30 40<br>50 75 100 |                |  |               |

## Inner structure and material of major parts

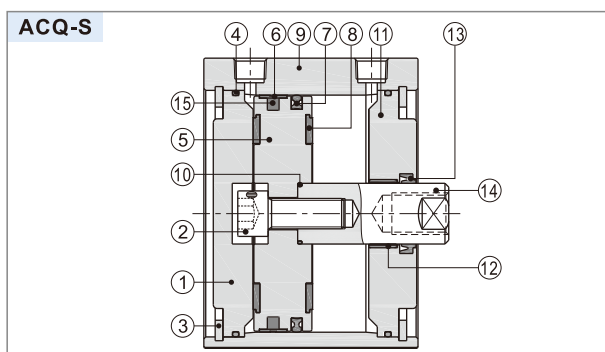

| NO. | Item        | Material                | NO. | Item                | Material                             |
|-----|-------------|-------------------------|-----|---------------------|--------------------------------------|
| 1   | Back cover  | Aluminum alloy          | 9   | Body                | Aluminum alloy                       |
| 2   | Screw       | Carbon steel            | 10  | O-ring              | NBR                                  |
| 3   | C clip      | Spring steel            | 11  | Front cover         | Aluminum alloy                       |
| 4   | O-ring      | NBR                     | 12  | Bushing             | Wear resistant material              |
| 5   | Piston      | Aluminum alloy          | 13  | Front cover packing | NBR                                  |
| 6   | Wear ring   | Wear resistant material | 14  | Piston rod          | Carbon steel with 20μm chrome plated |
| 7   | Piston seal | NBR                     | 15  | Magnet              | Rubber                               |
| 8   | Bumper      | NBR                     |     |                     |                                      |

# Compact cylinder

## ACQ Series—Big bore size

### Dimensions

#### ACQ

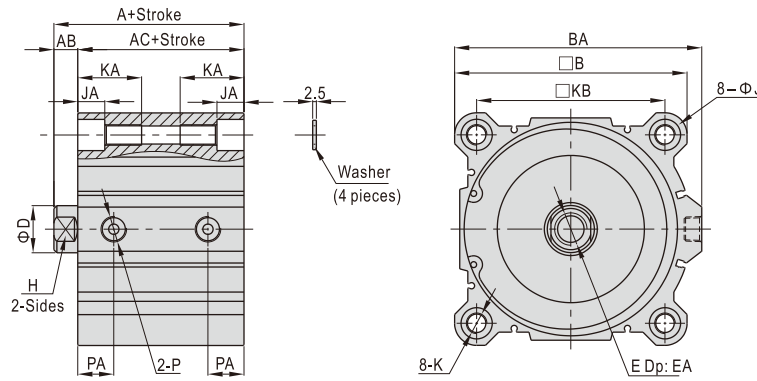

| Bore size\Item | A   | AB | AC | B   | BA  | D  | E       | EA(St≤10) | EA(St>10) | H  | J    | JA   | K                       | KA   | KB  | P    | PA   |
|----------------|-----|----|----|-----|-----|----|---------|-----------|-----------|----|------|------|-------------------------|------|-----|------|------|
| 125            | 99  | 16 | 83 | 142 | 153 | 32 | M22×2.5 | 22.5      | 30        | 27 | 21.2 | 18.4 | M14×2.0 Thru.hole:Φ12.4 | 43.5 | 114 | 3/8" | 24.5 |
| 140            | 99  | 16 | 83 | 158 | 168 | 32 | M22×2.5 | 22.5      | 30        | 27 | 21.2 | 18.4 | M14×2.0 Thru.hole:Φ12.4 | 43.5 | 128 | 3/8" | 24.5 |
| 160            | 108 | 17 | 91 | 178 | 188 | 40 | M24×3.0 | 26.5      | 33        | 36 | 24.2 | 21.2 | M16×2.0 Thru.hole:Φ14.4 | 49   | 144 | 3/8" | 27.5 |

Remark) Washer must be used when the cylinder be mounted by through hole. Please refer to this page for male thread dimensions.

#### ACQD

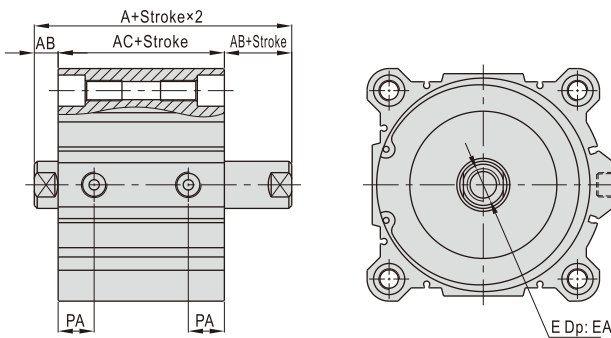

| Bore size\Item | A   | AB | AC | E       | EA    |       | PA   |
|----------------|-----|----|----|---------|-------|-------|------|
|                |     |    |    |         | St≤10 | St>10 |      |
| 125            | 115 | 16 | 83 | M22×2.5 | 22.5  | 30    | 24.5 |
| 140            | 115 | 16 | 83 | M22×2.5 | 22.5  | 30    | 24.5 |
| 160            | 125 | 17 | 91 | M24×3.0 | 26.5  | 33    | 27.5 |

Remark) The unmarked dimension is the same as ACQ standard type. Please refer to this page for male thread dimensions.

#### ACQJ

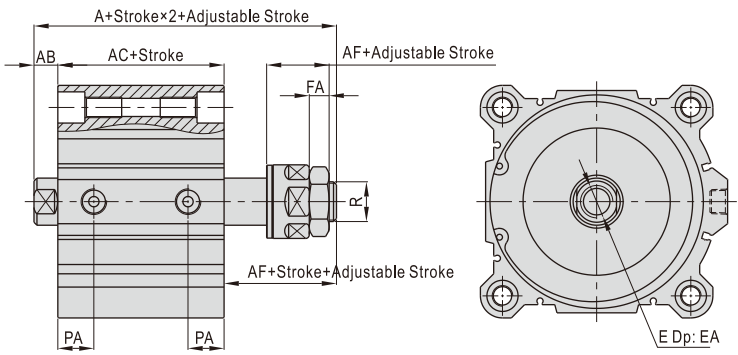

| Bore size\Item | A     | AB | AC | AF   | E       | EA    |       | FA   | PA   | R       |
|----------------|-------|----|----|------|---------|-------|-------|------|------|---------|
|                |       |    |    |      |         | St≤10 | St>10 |      |      |         |
| 125            | 140.8 | 16 | 83 | 42.5 | M22×2.5 | 22.5  | 30    | 13.5 | 24.5 | M27×2.0 |
| 140            | 140.8 | 16 | 83 | 42.5 | M22×2.5 | 22.5  | 30    | 13.5 | 24.5 | M27×2.0 |
| 160            | 175.3 | 17 | 91 | 68   | M24×3.0 | 26.5  | 33    | 18   | 27.5 | M36×2.0 |

Remark) The unmarked dimension is the same as ACQ standard type. Please refer to this page for male thread dimensions.

#### Male thread

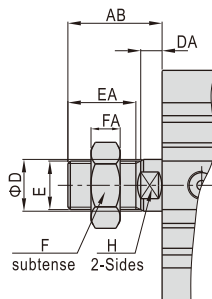

| Bore size\Item | AB | D  | E       | EA | EB | F  | FA | H  |
|----------------|----|----|---------|----|----|----|----|----|
| 125            | 58 | 32 | M30×1.5 | 42 | 45 | 46 | 18 | 27 |
| 140            | 58 | 32 | M30×1.5 | 42 | 45 | 46 | 18 | 27 |
| 160            | 64 | 40 | M36×1.5 | 47 | 50 | 55 | 21 | 36 |

# Compact cylinder

## ACQ Series—Longer stroke



### Symbol

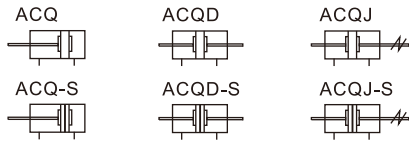

### Product feature

- JIS standard is implemented.
- C clip is adopted to connect the cylinder body and back cover or front cover, and riveted structure is adopted to connect piston and piston rod to make it compact and reliable.
- The internal diameter of the body is treated with rolling followed by the treatment of hard anodizing, forming an excellent abrasion resistance and durability.
- The seal of piston adopts heterogeneous two-way seal structure. It has compact dimension and the function of greasel reservation.
- Compact structure can effectively save installation space.
- There are magnetic switch slots around the cylinder body, which is convenient to install inducting switch.
- Installing accessories with various specifications are optional.

### Ordering code

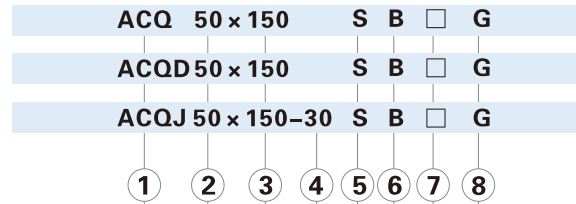

| ① Model                                    | ② Bore size           | ③ Stroke                          | ④ Adjustable Stroke      | ⑤ Magnet                                | ⑥ Rod type                             | ⑦ Mounting type [Note1]   | ⑧ Thread type |
|--|-----------------------|-----------------------------------|--------------------------|---|--|---|---------------|
| ACQ: Compact cylinder (Double acting)      | 32 40 50<br>63 80 100 | Refer to stroke table for details | No this code             | Blank: Without magnet<br>S: With magnet | Blank: Female thread<br>B: Male thread | Blank: No accessories<br>FA: FA type<br>FB: FB type<br>CB: CB type<br>LB: LB type | G: G Thread   |
| ACQD: Compact cylinder (Double rod)        |                       |                                   |                          |   |  |   |               |
| ACQJ: Compact cylinder (Adjustable stroke) |                       |                                   | 10 20 30 40<br>50 75 100 |   |  |   |               |

[Note1] Please refer to page 347~348 for accessory parts.

### Specification

| Bore size(mm)      | 32   | 40 | 50   | 63 | 80   | 100 |
|--------------------|--|----|------|----|------|-----|
| Acting type        | Double acting                              |    |      |    |      |     |
| Fluid              | Air(to be filtered by 40μm filter element) |    |      |    |      |     |
| Operating pressure | 0.15~1.0MPa(22~145psi)                     |    |      |    |      |     |
| Proof pressure     | 1.5MPa(215psi)                             |    |      |    |      |     |
| Temperature °C     | -20~70                                     |    |      |    |      |     |
| Speed range mm/s   | 30~500                                     |    |      |    |      |     |
| Stroke tolerance   | +1.5<br>0                                  |    |      |    |      |     |
| Cushion type       | Bumper                                     |    |      |    |      |     |
| Port size [Note1]  | 1/8"                                       |    | 1/4" |    | 3/8" |     |

[Note1] G thread is available.

Add) Refer to P568 for detail of sensor switch.

### Stroke

| Bore size(mm)      | Standard stroke (mm) |     |     |     |     |     | Max.std stroke |
|--------------------|----------------------|-----|-----|-----|-----|-----|----------------|
| 32 40 50 63 80 100 | 125                  | 150 | 175 | 200 | 250 | 300 | 300            |

Note) Within allowable stroke scope, when the stroke is larger than the maximum value, it shall be treated as non-standard one. Please contact the company for other special strokes.

### Inner structure and material of major parts

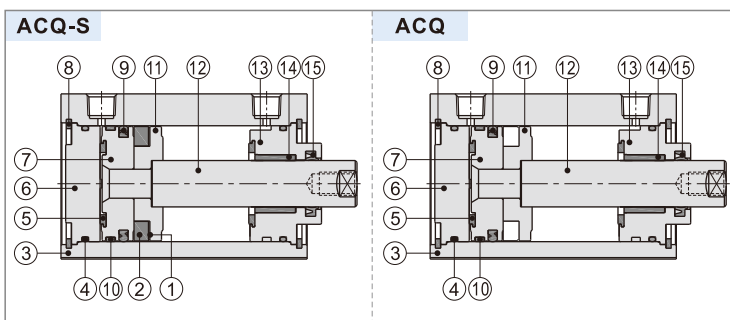

| NO. | Item          | Material       | NO. | Item                | Material                                |
|-----|---------------|----------------|-----|---------------------|---|
| 1   | Magnet washer | NBR            | 10  | Wear ring           | No(Φ32)\Wear resistant material(Others) |
| 2   | Magnet        | Plastic        | 11  | Magnet holder       | Aluminum alloy                          |
| 3   | Body          | Aluminum alloy | 12  | Piston rod          | Carbon steel with 20μm chrome plated    |
| 4   | O-ring        | NBR            | 13  | Front cover         | Aluminum alloy                          |
| 5   | Bumper        | NBR            | 14  | Bushing             | No(Φ32)\Wear resistant material(Others) |
| 6   | Back cover    | Aluminum alloy | 15  | Front cover packing | NBR                                     |
| 7   | Piston        | Aluminum alloy |     |                     |   |
| 8   | C clip        | Spring steel   |     |                     |   |
| 9   | Piston seal   | NBR            |     |                     |   |



# Compact cylinder

## ACQ Series—Longer stroke

### Dimensions

#### ACQ

φ32-φ100(Stroke > 100)

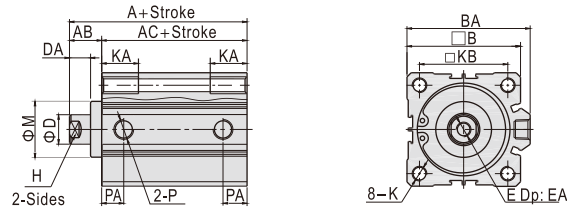

| Bore size\Item | A    | AB | AC   | B   | BA    | D  | DA | E       | EA | H  | K                        | KA | KB | M  | P    | PA   |
|----------------|------|----|------|-----|-------|----|----|---------|----|----|--------------------------|----|----|----|------|------|
| 32             | 62.5 | 17 | 45.5 | 45  | 49.5  | 16 | 12 | M8×1.25 | 13 | 14 | M6×1.0 Thru.hole:φ5.2    | 17 | 34 | 22 | 1/8" | 12.5 |
| 40             | 72   | 17 | 55   | 53  | 57    | 16 | 12 | M8×1.25 | 13 | 14 | M6×1.0 Thru.hole:φ5.2    | 17 | 40 | 28 | 1/8" | 14   |
| 50             | 73.5 | 18 | 55.5 | 64  | 71    | 20 | 13 | M10×1.5 | 15 | 17 | M8×1.25 Thru.hole:φ6.7   | 22 | 50 | 35 | 1/4" | 14   |
| 63             | 75   | 18 | 57   | 77  | 84    | 20 | 13 | M10×1.5 | 15 | 17 | M10×1.5 Thru.hole:φ8.5   | 27 | 60 | 35 | 1/4" | 16.5 |
| 80             | 86   | 20 | 66   | 98  | 104   | 25 | 15 | M16×2.0 | 21 | 22 | M12×1.75 Thru.hole:φ10.4 | 32 | 77 | 43 | 3/8" | 19   |
| 100            | 97.5 | 22 | 75.5 | 117 | 123.5 | 32 | 17 | M20×2.5 | 27 | 27 | M12×1.75 Thru.hole:φ10.4 | 33 | 94 | 59 | 3/8" | 23   |

#### ACQD

φ32-φ100(Stroke > 100)

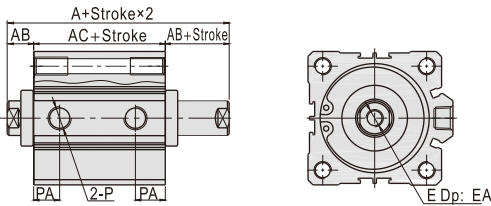

#### ACQJ

φ32-φ100(Stroke > 100)

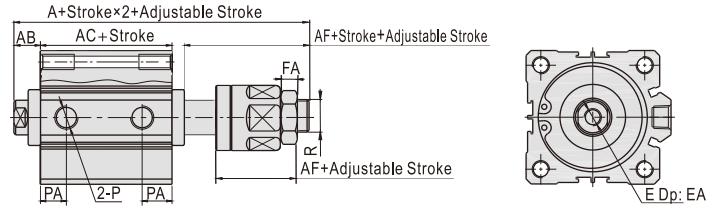

| Bore size\Item | A(ACQD)        |             | A(ACQJ)        |             | AB | AC             |             | AF   | EA | FA   | PA   | R        |
|----------------|----------------|-------------|----------------|-------------|----|----------------|-------------|------|----|------|------|----------|
|                | Without magnet | With magnet | Without magnet | With magnet |    | Without magnet | With magnet |      |    |      |      |          |
| 32             | 79.5           | 89.5        | 95.5           | 105.5       | 17 | 45.5           | 55.5        | 28   | 13 | 7    | 12.5 | M12×1.25 |
| 40             | 89             | 99          | 105            | 115         | 17 | 55             | 65          | 28   | 13 | 7    | 14   | M12×1.25 |
| 50             | 91.5           | 101.5       | 107.5          | 117.5       | 18 | 55.5           | 65.5        | 29   | 15 | 8    | 14   | M16×1.5  |
| 63             | 93             | 103         | 109            | 119         | 18 | 57             | 67          | 29   | 15 | 8    | 16.5 | M16×1.5  |
| 80             | 106            | 116         | 126.5          | 136.5       | 20 | 66             | 76          | 35.5 | 21 | 10   | 19   | M20×1.5  |
| 100            | 119.5          | 129.5       | 145            | 155         | 22 | 75.5           | 85.5        | 42.5 | 27 | 13.5 | 23   | M27×2.0  |

Remark) The unmarked dimension is the same as ACQ standard type.

#### Male thread (Bore size: φ32-φ100 Stroke>100 Longer type)

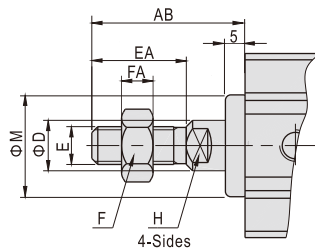

| Bore size\Item | AB   | D  | E       | EA | FA | F  | H  | M  |
|----------------|------|----|---------|----|----|----|----|----|
| 32             | 38.5 | 16 | M14×1.5 | 23 | 8  | 19 | 14 | 22 |
| 40             | 38.5 | 16 | M14×1.5 | 23 | 8  | 19 | 14 | 28 |
| 50             | 43.5 | 20 | M18×1.5 | 28 | 11 | 27 | 17 | 35 |
| 63             | 43.5 | 20 | M18×1.5 | 28 | 11 | 27 | 17 | 35 |
| 80             | 53.5 | 25 | M22×1.5 | 35 | 13 | 32 | 22 | 43 |
| 100            | 53.5 | 32 | M26×1.5 | 35 | 13 | 36 | 27 | 59 |

# Compact cylinder

ACQ Series—With guider type



## Symbol

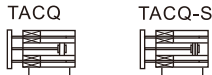

## Product feature

1. JIS standard is implemented and with guider.
2. C clip is adopted to connect the cylinder body and back cover or front cover to make it compact and reliable.
3. The internal diameter of the body is treated with rolling followed by the treatment of hard anodizing, forming an excellent abrasion resistance and durability.
4. The seal of piston adopts heterogeneous two-way seal structure. It has compact dimension and the function of greasel reservation.
5. Compact structure can effectively save installation space.
6. There are magnetic switch slots around the cylinder body, which is convenient to install inducting switch.
7. Double rod non-rotating structure enables to bear large working load and lateral load.

## Ordering code

TACQ 50 × 100 S G



| ① Model  | ② Bore size                    | ③ Stroke                          | ④ Magnet                                | ⑤ Thread type |
|--|--------------------------------|-----------------------------------|---|---------------|
| TACQ: Compact cylinder (Double acting with guider) | 12 16 20 25 32 40 50 63 80 100 | Refer to stroke table for details | Blank: Without magnet<br>S: With magnet | G: G Thread   |

## Specification

| Bore size(mm)                  | 12   | 16 | 20 | 25 | 32 | 40     | 50 | 63   | 80 | 100  |
|--------------------------------|--|----|----|----|----|--------|----|------|----|------|
| Acting type                    | Double acting                              |    |    |    |    |        |    |      |    |      |
| Fluid                          | Air(to be filtered by 40μm filter element) |    |    |    |    |        |    |      |    |      |
| Operating pressure             | 0.15~1.0MPa(22~145psi)                     |    |    |    |    |        |    |      |    |      |
| Proof pressure                 | 1.5MPa(215psi)                             |    |    |    |    |        |    |      |    |      |
| Temperature °C                 | -20~70                                     |    |    |    |    |        |    |      |    |      |
| Speed range mm/s               | 30~500                                     |    |    |    |    |        |    |      |    |      |
| Stroke tolerance               | +1.0<br>0                                  |    |    |    |    |        |    |      |    |      |
| Cushion type                   | Bumper                                     |    |    |    |    |        |    |      |    |      |
| Port size [Note1]              | M5×0.8                                     |    |    |    |    | 1/8"   |    | 1/4" |    | 3/8" |
| Non-rotating tolerance [Note2] | ±0.2°                                      |    |    |    |    | ±0.15° |    |      |    |      |

[Note1] G thread is available.

[Note2] Retract position.

Add) Refer to P568 for detail of sensor switch.

## Stroke

| Bore size(mm) | Standard stroke (mm) |    |    |    |    |    |    |    |    |    |    | Max.std stroke (mm) | Middle stroke range(mm) |      |
|---------------|----------------------|----|----|----|----|----|----|----|----|----|----|---------------------|-------------------------|------|
|               | 5                    | 10 | 15 | 20 | 25 | 30 | 35 | 40 | 45 | 50 | 75 |                     |                         | 100  |
| 12 16         | ●                    | ●  | ●  | ●  | ●  | ●  | ×  | ×  | ×  | ×  | ×  | ×                   | 30                      | 1~29 |
| 20 25         | ●                    | ●  | ●  | ●  | ●  | ●  | ●  | ●  | ●  | ×  | ×  | ●                   | 50                      | 1~49 |
| 32 40         | ●                    | ●  | ●  | ●  | ●  | ●  | ●  | ●  | ●  | ●  | ●  | ●                   | 100                     | 1~99 |
| 50 63 80 100  | ×                    | ●  | ●  | ●  | ●  | ●  | ●  | ●  | ●  | ●  | ●  | ●                   | 100                     | 5~99 |

[Note] The dimensions of non-std stroke cylinder has the same dimensions as the next longer stroke std. stroke cylinder. e.g. 23mm stroke cylinder has the same dimensions of 25 std. stroke cylinder.

Please contact the company for other special strokes.

## Inner structure and material of major parts

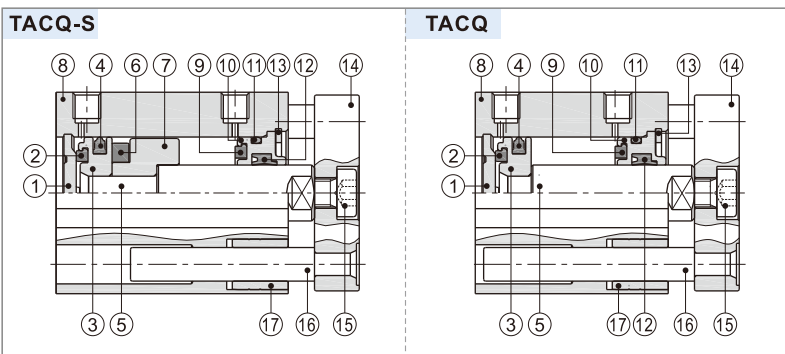

| NO. | Item          | Material                              | NO. | Item                | Material  |
|-----|---------------|---------------------------------------|-----|---------------------|---|
| 1   | Back cover    | Aluminum alloy                        | 10  | Front cover         | Aluminum alloy                                  |
| 2   | Bumper        | NBR                                   | 11  | O-ring              | NBR   |
| 3   | Piston        | Aluminum alloy                        | 12  | Front cover packing | NBR   |
| 4   | Piston seal   | NBR                                   |     |                     |   |
| 5   | Piston rod    | Carbon steel with 20μm chrome plated  | 13  | C clip              | Spring steel                                    |
| 6   | Magnet        | Sintered metal (Neodymium-iron-boron) | 14  | Fixing plate        | Aluminum alloy                                  |
| 7   | Magnet holder | Aluminum alloy                        | 15  | Screw               | Carbon steel                                    |
| 8   | Body          | Aluminum alloy                        |     |                     |   |
| 9   | Wear ring     | NBR                                   | 16  | Leader              | Carbon steel with 20μm chrome plated (Φ50~Φ100) |
|     |               |                                       | 17  | Bushing             | Brass   |



# Compact cylinder

## ACQ Series—With guider type

### Installation and application

1. TACQ series cylinder is designed with double guide rod which is non-rotating. Make sure the non-rotating accuracy of the fixing plate is in the allowable range.

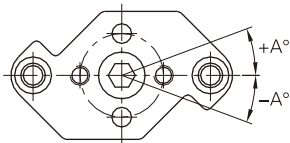

| Bore size              | 12,16 | 20,25,32,40,50,63,80,100 |
|------------------------|-------|--------------------------|
| Non-rotating tolerance | ±0.2° | ±0.15°                   |

2. Do not apply reverse torque to the piston rods. The torque beyond the limits may cause malfunction or reduction of the service life.

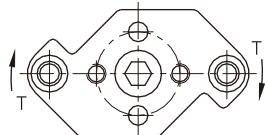

Unit: N·m

| Bore size\Stroke | 5    | 10    | 15    | 20    | 25    | 30   | 35   | 40   | 45   | 50   | 75   | 100  |
|------------------|------|-------|-------|-------|-------|------|------|------|------|------|------|------|
| 12               | 0.11 | 0.10  | 0.08  | 0.07  | 0.07  | 0.06 | -    | -    | -    | -    | -    | -    |
| 16               | 0.15 | 0.12  | 0.11  | 0.10  | 0.09  | 0.08 | -    | -    | -    | -    | -    | -    |
| 20               | 0.37 | 0.32  | 0.28  | 0.25  | 0.23  | 0.21 | 0.19 | 0.18 | 0.17 | 0.16 | -    | -    |
| 25               | 0.40 | 0.35  | 0.31  | 0.28  | 0.25  | 0.23 | 0.21 | 0.20 | 0.18 | 0.17 | -    | -    |
| 32               | 0.66 | 0.59  | 0.53  | 0.49  | 0.45  | 0.42 | 0.39 | 0.36 | 0.34 | 0.32 | 0.25 | 0.20 |
| 40               | 1.06 | 0.96  | 0.88  | 0.81  | 0.75  | 0.70 | 0.65 | 0.61 | 0.58 | 0.55 | 0.43 | 0.36 |
| 50               | -    | 1.70  | 1.56  | 1.45  | 1.35  | 1.26 | 1.19 | 1.12 | 1.06 | 1.01 | 0.80 | 0.67 |
| 63               | -    | 3.90  | 3.62  | 3.37  | 3.15  | 2.96 | 2.80 | 2.65 | 2.51 | 2.39 | 1.92 | 1.61 |
| 80               | -    | 7.44  | 6.98  | 6.56  | 6.20  | 5.87 | 5.57 | 5.31 | 5.07 | 4.84 | 3.98 | 3.37 |
| 100              | -    | 11.85 | 11.19 | 10.61 | 10.08 | 9.60 | 9.17 | 8.77 | 8.41 | 8.07 | 6.73 | 5.77 |

3. Make sure the lateral load on the mounting bracket is within the limits. Any exceeding may cause malfunction or reduction of the service life.

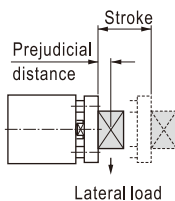
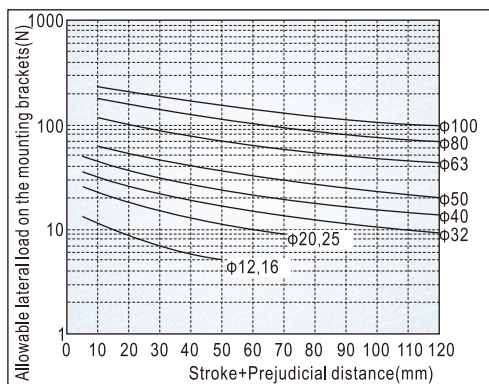

4. Make sure the load quality and the maximum speed are within the limits. Any exceeding may cause malfunction or reduction of the service life.

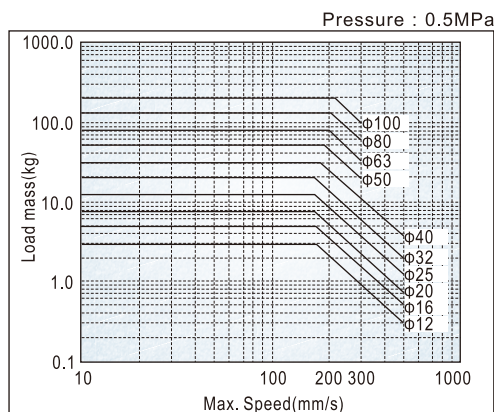

5. Caution before mounting:

- 5.1) Do not put hands between the mounting bracket and cylinder, which may cause damage to a human body when the piston rod retracts.

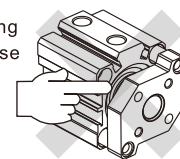

- 5.2) Make sure the external force against the mounting bracket is concentric with the piston rod. Any extra torque may cause damage to the cylinder.

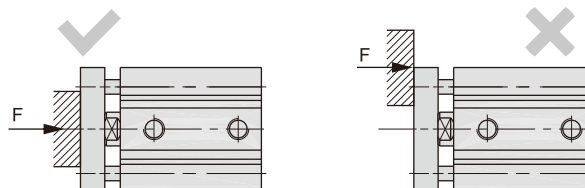

- 5.3) Install the fixture onto the mounting bracket only when the piston rod is in the retraction state. Do not apply the installation torque on the guide rod.
- 5.4) Avoid any damage on piston rod and guide rod, which may cause damage on seals and air leakage or malfunction.

# Compact cylinder

## ACQ Series—With guider type

### Dimensions

Φ12/Φ16

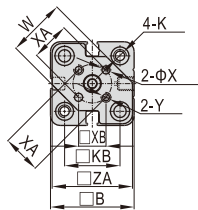
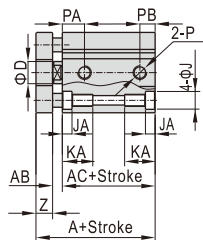

Φ20/Φ25

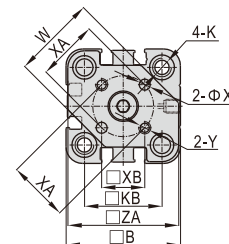
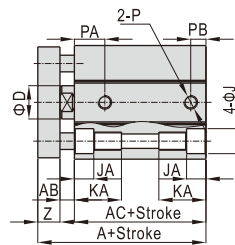

| Bore size\Item | A              |             | AC             |             | AB  | B  | D  | J | JA  | K                     |
|----------------|----------------|-------------|----------------|-------------|-----|----|----|---|-----|-----------------------|
|                | Without magnet | With magnet | Without magnet | With magnet |     |    |    |   |     |                       |
| 12             | 26.5           | 37.5        | 17.3           | 28.3        | 3   | 26 | 6  | 6 | 3.5 | M4×0.7 Thru.hole:Φ3.4 |
| 16             | 28             | 40          | 19             | 31          | 3   | 30 | 8  | 6 | 3.5 | M4×0.7 Thru.hole:Φ3.4 |
| 20             | 32             | 44          | 20.5           | 32.5        | 3.5 | 36 | 10 | 9 | 5.5 | M6×1.0 Thru.hole:Φ5.2 |
| 25             | 35.5           | 45.5        | 23             | 33          | 4.5 | 41 | 12 | 9 | 5.5 | M6×1.0 Thru.hole:Φ5.2 |

| Bore size\Item | KA | KB   | P      | PA             |             | PB             |             | W  | X | XA | XB   | Y      | Z | ZA |
|----------------|----|------|--------|----------------|-------------|----------------|-------------|----|---|----|------|--------|---|----|
|                |    |      |        | Without magnet | With magnet | Without magnet | With magnet |    |   |    |      |        |   |    |
| 12             | 11 | 15.5 | M5×0.8 | 7.5            | 9           | 5              | 7           | 15 | 3 | 10 | 7.1  | M3×0.5 | 6 | 25 |
| 16             | 11 | 20   | M5×0.8 | 8.5            | 10          | 5.5            | 7.5         | 21 | 3 | 14 | 9.9  | M3×0.5 | 6 | 29 |
| 20             | 17 | 25.5 | M5×0.8 | 10             | 10.5        | 5.5            | 5.5         | 26 | 4 | 17 | 12   | M4×0.7 | 8 | 35 |
| 25             | 17 | 28   | M5×0.8 | 11.5           | 11.5        | 5.5            | 5.5         | 30 | 5 | 22 | 15.6 | M5×0.8 | 8 | 40 |

Φ32~Φ100

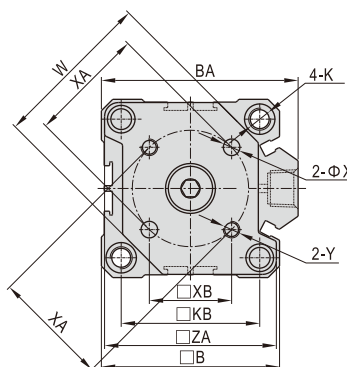
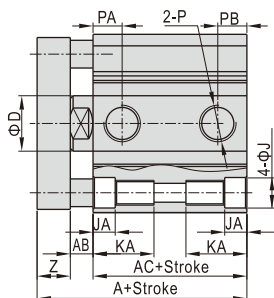

| Bore size\Item | A (Without magnet) |       | A (With magnet) | AB  | AC (Without magnet) |       | AC (With magnet) | B   | BA    | D  | J    | JA  | K                        |
|----------------|--------------------|-------|-----------------|-----|---------------------|-------|------------------|-----|-------|----|------|-----|--------------------------|
|                | St≤50              | St≥75 |                 |     | St≤50               | St≥75 |                  |     |       |    |      |     |                          |
| 32             | 40                 | 50    | 50              | 6.5 | 23.5                | 33.5  | 33.5             | 45  | 49.5  | 16 | 9    | 5.5 | M6×1.0 Thru.hole:Φ5.2    |
| 40             | 46.5               | 56.5  | 56.5            | 6.6 | 30                  | 40    | 40               | 53  | 57    | 16 | 9    | 5.5 | M6×1.0 Thru.hole:Φ5.2    |
| 50             | 50.5               | 60.5  | 60.5            | 7.5 | 31                  | 41    | 41               | 64  | 71    | 20 | 10.5 | 6.5 | M8×1.25 Thru.hole:Φ6.8   |
| 63             | 56                 | 66    | 66              | 8   | 36                  | 46    | 46               | 77  | 84    | 20 | 14   | 9   | M10×1.5 Thru.hole:Φ8.5   |
| 80             | 67.5               | 77.5  | 77.5            | 10  | 43.5                | 53.5  | 53.5             | 98  | 104   | 25 | 17   | 11  | M12×1.75 Thru.hole:Φ10.4 |
| 100            | 81                 | 91    | 91              | 12  | 53                  | 63    | 63               | 117 | 123.5 | 32 | 17   | 11  | M12×1.75 Thru.hole:Φ10.4 |

| Bore size\Item | KA   | KB | P    | PA               | PA            | PB               | PB            | W     | X  | XA | XB   | Y       | Z  | ZA    |
|----------------|------|----|------|------------------|---------------|------------------|---------------|-------|----|----|------|---------|----|-------|
|                |      |    |      | (Without magnet) | (With magnet) | (Without magnet) | (With magnet) |       |    |    |      |         |    |       |
| 32             | 17   | 34 | 1/8" | 8                | 10.5          | 6.5              | 7.5           | 37    | 5  | 28 | 19.8 | M5×0.8  | 10 | 43    |
|                |      |    |      | 11               |               | 7.5              |               |       |    |    |      |         |    |       |
| 40             | 17   | 40 | 1/8" | 11               | 11            | 8                | 8             | 46    | 5  | 33 | 23.3 | M5×0.8  | 10 | 51    |
| 50             | 22   | 50 | 1/4" | 10.5             | 11            | 11               | 10.5          | 58    | 6  | 42 | 29.7 | M6×1.0  | 12 | 62    |
| 63             | 28.5 | 60 | 1/4" | 15               | 15            | 10.5             | 10.5          | 69    | 6  | 50 | 35.4 | M6×1.0  | 12 | 75    |
| 80             | 35.5 | 77 | 3/8" | 16               | 16            | 14               | 14            | 90    | 8  | 65 | 46   | M8×1.25 | 14 | 95    |
| 100            | 35.5 | 94 | 3/8" | 20               | 20            | 17.5             | 17.5          | 113.5 | 10 | 80 | 56.6 | M10×1.5 | 16 | 114.5 |

# Compact cylinder

## ACQ Series—Accessories

### List for ordering code of accessories

| Accessories<br>Bore size | Mounting accessories |            |            | Knuckle   |           |            |            | Sensor switch                          |
|--------------------------|----------------------|------------|------------|-----------|-----------|------------|------------|--|
|                          | LB                   | FA/FB      | CB         | I         | Y         | F          | U          |  |
| 12                       | F-ACQ12LB            | F-ACQ12FA  | F-ACQ12CB  | F-ACQ12I  | F-ACQ12Y  | -          | F-M5X080U  | CMSG<br>DMSG<br>EMSG                   |
| 16                       | F-ACQ16LB            | F-ACQ16FA  | F-ACQ16CB  | F-ACQ16I  | F-ACQ16Y  | -          | F-M6X100U  |  |
| 20                       | F-ACQ20LB            | F-ACQ20FA  | F-ACQ20CB  | F-ACQ20I  | F-ACQ20Y  | F-M8X125F  | F-M8X125U  |  |
| 25                       | F-ACQ25LB            | F-ACQ25FA  | F-ACQ25CB  | F-ACQ25I  | F-ACQ25Y  | F-M10X125F | F-M10X125U | CMSJ<br>DMSJ<br>CMSG<br>DMSG<br>EMSG   |
| 32                       | F-ACQ32LB            | F-ACQ32FA  | F-ACQ32CB  | F-ACQ32I  | F-ACQ32Y  | F-M14X150F | F-M14X150U |  |
| 40                       | F-ACQ40LB            | F-ACQ40FA  | F-ACQ40CB  |           |           |            |            |  |
| 50                       | F-ACQ50LB            | F-ACQ50FA  | F-ACQ50CB  | F-ACQ50I  | F-ACQ50Y  | F-M18X150F | F-M18X150U |  |
| 63                       | F-ACQ63LB            | F-ACQ63FA  | F-ACQ63CB  |           |           |            |            |  |
| 80                       | F-ACQ80LB            | F-ACQ80FA  | F-ACQ80CB  |           |           |            |            | F-ACQ80I                               |
| 100                      | F-ACQ100LB           | F-ACQ100FA | F-ACQ100CB | F-ACQ100I | F-ACQ100Y | -          | F-M26X150U | CMSH/DMSH<br>EMSH<br>CMSG/DMSG<br>EMSG |
| 125                      | -                    | -          | -          |           |           |            |            |  |
| 140                      | -                    | -          | -          |           |           |            |            |  |
| 160                      | -                    | -          | -          |           |           |            |            |  |

### Accessory selection

| Cylinder model | Accessories   | Mounting accessories |    |    |        | Knuckle[Note2] |   |   |   | Sensor switch[Note3] |                   |                   |
|----------------|---------------|----------------------|----|----|--------|----------------|---|---|---|----------------------|-------------------|-------------------|
|                |               | LB                   | FA | FB | CB [1] | I              | Y | U | F | CMSJ<br>DMSJ         | CMSG/DMSG<br>EMSG | CMSH/DMSH<br>EMSH |
| ACQ            | Female thread | Without magnet       |    |    |        | x              | x | x | x | x                    | x                 | x                 |
|                |               | With magnet          | •  | •  | •      | •              | • | • | • | •                    | •                 | •                 |
|                | Male thread   | Without magnet       |    |    |        | •              | • | • | • | x                    | x                 | x                 |
|                |               | With magnet          | •  | •  | •      | •              | • | • | • | •                    | •                 | •                 |
| ASQ<br>ATQ     | Female thread | Without magnet       |    |    |        | x              | x | x | x | x                    | x                 | x                 |
|                |               | With magnet          | •  | •  | •      | •              | • | • | • | •                    | •                 | •                 |
|                | Male thread   | Without magnet       |    |    |        | •              | • | • | • | x                    | x                 | x                 |
|                |               | With magnet          | •  | •  | •      | •              | • | • | • | •                    | •                 | •                 |
| ACQD<br>ACQJ   | Female thread | Without magnet       |    |    |        | x              | x | x | x | x                    | x                 | x                 |
|                |               | With magnet          | •  | •  | x      | •              | • | • | • | •                    | •                 | •                 |
|                | Male thread   | Without magnet       |    |    |        | •              | • | • | • | x                    | x                 | x                 |
|                |               | With magnet          | •  | •  | x      | •              | • | • | • | •                    | •                 | •                 |

### Material of accessories

| Accessories<br>Bore size | Mounting accessories |    |    |    | Knuckle |   |   |   |
|--------------------------|----------------------|----|----|----|---------|---|---|---|
|                          | LB                   | FA | FB | CB | I       | Y | F | U |
| 12, 15                   | △                    | ●  | ●  | ●  | ▲       | ▲ | ▲ | ▲ |
| 20, 25                   | △                    | ●  | ●  | ●  | ▲       | ▲ | ▲ | ▲ |
| 32~100                   | △                    | ●  | ●  | ■  | ▲       | ■ | ▲ | ▲ |

●—Aluminum alloy ; ■—Carbon Steel  
▲—S45C ; △—SPCC

[Note1] CB is attached with relevant PIN.  
Mounting accessories and Knuckle unavailable for bore size 125,140,160 cylinder.  
[Note2] Please refer to P564~567 for knuckle detail.

### Dimensions

#### FA/FB

φ12~φ25

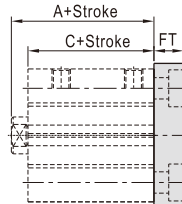
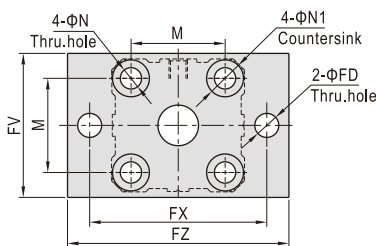

φ32~φ100

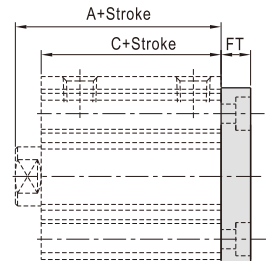
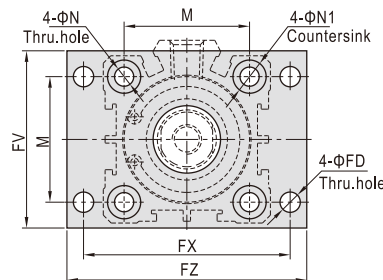

| Bore size/Item | A [Note1]      |     |             |      | C              |      |             |      | M    | N    | N1   | FD  | FT  | FV   | FX  | FZ  |
|----------------|----------------|-----|-------------|------|----------------|------|-------------|------|------|------|------|-----|-----|------|-----|-----|
|                | Without magnet |     | With magnet |      | Without magnet |      | With magnet |      |      |      |      |     |     |      |     |     |
|                | Stroke         | ≤50 | 55          | ≥60  | Stroke         | ≤50  | 55          | ≥60  |      |      |      |     |     |      |     |     |
| 12             | 20.5           | -   | -           | 31.5 | 17             | -    | -           | 28   | 15.5 | 4.5  | 7.5  | 4.5 | 5.5 | 25   | 45  | 55  |
| 16             | 22             | 22  | -           | 34   | 18.5           | 18.5 | -           | 30.5 | 20   | 4.5  | 7.5  | 4.5 | 5.5 | 30   | 45  | 55  |
| 20             | 24             | -   | 34          | 36   | 19.5           | -    | 29.5        | 31.5 | 25.5 | 6.5  | 10.5 | 6.5 | 8   | 39.5 | 48  | 60  |
| 25             | 27.5           | -   | 37.5        | 37.5 | 22.5           | -    | 32.5        | 32.5 | 28   | 6.5  | 10.5 | 6.5 | 8   | 42   | 52  | 64  |
| 32             | 30             | -   | 40          | 40   | 23             | -    | 33          | 33   | 34   | 6.5  | 10.5 | 5.5 | 8   | 48   | 56  | 65  |
| 40             | 36.5           | -   | 46.5        | 46.5 | 29.5           | -    | 39.5        | 39.5 | 40   | 6.5  | 10.5 | 5.5 | 8   | 54   | 62  | 72  |
| 50             | 38.5           | -   | 48.5        | 48.5 | 30.5           | -    | 40.5        | 40.5 | 50   | 8.5  | 13.5 | 6.5 | 9   | 67   | 76  | 89  |
| 63             | 44             | -   | 54          | 54   | 36             | -    | 46          | 46   | 60   | 10.5 | 16.5 | 9   | 10  | 80   | 92  | 108 |
| 80             | 53.5           | -   | 63.5        | 63.5 | 43.5           | -    | 53.5        | 53.5 | 77   | 12.5 | 18.5 | 11  | 12  | 99   | 116 | 134 |
| 100            | 65             | -   | 75          | 75   | 53             | -    | 63          | 63   | 94   | 12.5 | 18.5 | 11  | 12  | 117  | 136 | 154 |

[Note] Value A and C in the above table are only for ACQ series.  
Please refer to relevant content for value A and C of other series.

# Compact cylinder

## ACQ Series—Accessories

### LB

φ12-φ25

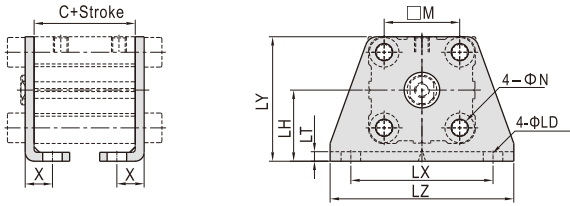

φ32-φ100

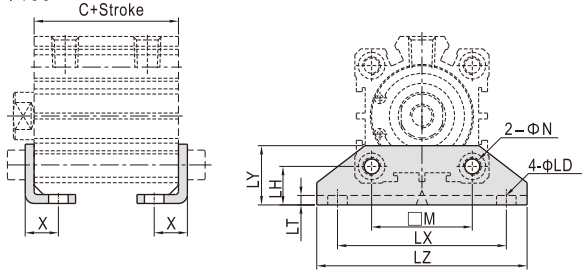

### CB

φ12-φ25

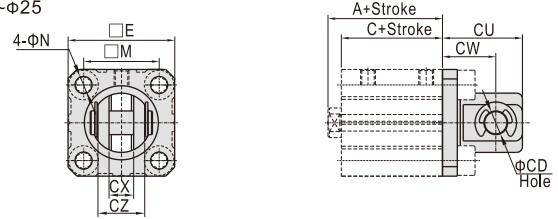

φ32-φ100

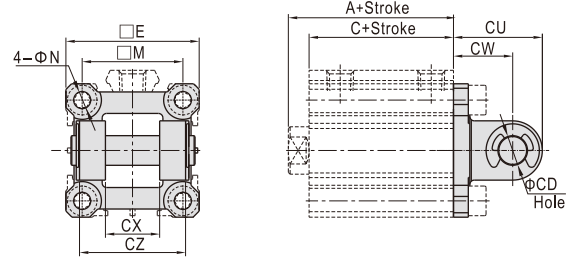

| Bore size/Item | C [Note]       |      |             | M    | N    | X    | LD   | LH   | LT   | LX  | LY  | LZ   |     |
|----------------|----------------|------|-------------|------|------|------|------|------|------|-----|-----|------|-----|
|                | Without magnet |      | With magnet |      |      |      |      |      |      |     |     |      |     |
| Stroke         | ≤50            | 55   | ≥60         |      |      |      |      |      |      |     |     |      |     |
| 12             | 17             | -    | -           | 28   | 15.5 | 4.5  | 8    | 4.5  | 17   | 2   | 34  | 29.5 | 44  |
| 16             | 18.5           | 18.5 | -           | 30.5 | 20   | 4.5  | 8    | 4.5  | 19   | 2   | 38  | 33.5 | 48  |
| 20             | 19.5           | -    | 29.5        | 31.5 | 25.5 | 6.5  | 9.2  | 6.5  | 24   | 3   | 48  | 42   | 62  |
| 25             | 22.5           | -    | 32.5        | 32.5 | 28   | 6.5  | 10.7 | 6.5  | 26   | 3   | 52  | 46   | 66  |
| 32             | 23             | -    | 33          | 33   | 34   | 6.5  | 11.2 | 6.5  | 13   | 3   | 57  | 20   | 71  |
| 40             | 29.5           | -    | 39.5        | 39.5 | 40   | 6.5  | 11.2 | 6.5  | 13   | 3   | 64  | 20   | 78  |
| 50             | 30.5           | -    | 40.5        | 40.5 | 50   | 8.5  | 12.2 | 8.5  | 14   | 3   | 79  | 22   | 95  |
| 63             | 36             | -    | 46          | 46   | 60   | 10.5 | 13.7 | 10.5 | 16   | 3   | 95  | 26   | 113 |
| 80             | 43.5           | -    | 53.5        | 53.5 | 77   | 13   | 16.5 | 13   | 20.5 | 4.5 | 118 | 32   | 140 |
| 100            | 53             | -    | 63          | 63   | 94   | 13   | 23   | 13   | 24   | 6   | 137 | 36   | 162 |

[Note] Value C in the above table is only for ACQ series.  
Please refer to relevant content for value C of other series.

| Item             | A [Note]       |    |             | C              |             |                | E           | M    | N     | CD   | CU   | CW | CX | CZ |      |      |
|------------------|----------------|----|-------------|----------------|-------------|----------------|-------------|------|-------|------|------|----|----|----|------|------|
|                  | Without magnet |    | With magnet | Without magnet |             | With magnet    |             |      |       |      |      |    |    |    |      |      |
| Bore size/Stroke | ≤50            | 55 | ≥60         | Without magnet | With magnet | Without magnet | With magnet |      |       |      |      |    |    |    |      |      |
| 12               | 20.5           | -  | -           | 31.5           | 17          | -              | -           | 28   | 25    | 15.5 | 4.5  | 5  | 20 | 14 | 5.3  | 9.8  |
| 16               | 22             | 22 | -           | 34             | 18.5        | 18.5           | -           | 30.5 | 29    | 20   | 4.5  | 5  | 21 | 15 | 6.8  | 11.8 |
| 20               | 24             | -  | 34          | 36             | 19.5        | -              | 29.5        | 31.5 | 36    | 25.5 | 6.5  | 8  | 27 | 18 | 8.3  | 15.8 |
| 25               | 27.5           | -  | 37.5        | 37.5           | 22.5        | -              | 32.5        | 32.5 | 40    | 28   | 6.5  | 10 | 30 | 20 | 10.3 | 19.8 |
| 32               | 30             | -  | 40          | 40             | 23          | -              | 33          | 33   | 45.5  | 34   | 6.5  | 10 | 30 | 20 | 18.3 | 35.8 |
| 40               | 36.5           | -  | 46.5        | 46.5           | 29.5        | -              | 39.5        | 39.5 | 53.5  | 40   | 6.5  | 10 | 32 | 22 | 18.3 | 35.8 |
| 50               | 38.5           | -  | 48.5        | 48.5           | 30.5        | -              | 40.5        | 40.5 | 64.5  | 50   | 8.5  | 14 | 42 | 28 | 22.3 | 43.8 |
| 63               | 44             | -  | 54          | 54             | 36          | -              | 46          | 46   | 77.5  | 60   | 10.5 | 14 | 44 | 30 | 22.3 | 43.8 |
| 80               | 53.5           | -  | 63.5        | 63.5           | 43.5        | -              | 53.5        | 53.5 | 98.5  | 77   | 12.5 | 18 | 56 | 38 | 28.3 | 55.8 |
| 100              | 65             | -  | 75          | 75             | 53          | -              | 63          | 63   | 117.5 | 94   | 12.5 | 22 | 67 | 45 | 32.3 | 63.8 |

[Note] Value A and C in the above table are only for ACQ series.  
Please refer to relevant content for value A and C of other series.

### Y Knuckle

F-ACQ12Y  
F-ACQ16Y  
F-ACQ20Y  
F-ACQ25Y

F-ACQ32Y  
F-ACQ50Y  
F-ACQ80Y  
F-ACQ100Y

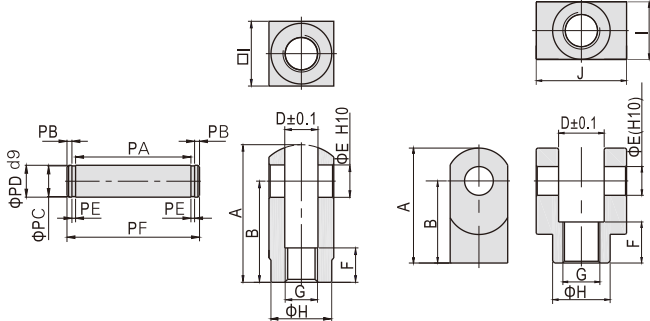

| Type/Item | A  | B  | D    | E  | F    | G        | H  | I  | J  | PA   | PB  | PC | PD | PE  | PF   |
|-----------|----|----|------|----|------|----------|----|----|----|------|-----|----|----|-----|------|
| F-ACQ12Y  | 22 | 16 | 5.3  | 5  | 6    | M5×0.8   | 9  | 10 | -  | 10.2 | 1.5 | 4  | 5  | 0.7 | 14.6 |
| F-ACQ16Y  | 28 | 21 | 6.6  | 5  | 11   | M6×1.0   | 11 | 12 | -  | 12.4 | 1.5 | 4  | 5  | 0.7 | 16.8 |
| F-ACQ20Y  | 34 | 25 | 8.3  | 8  | 8.5  | M8×1.25  | 15 | 16 | -  | 16.2 | 1.5 | 7  | 8  | 0.9 | 21   |
| F-ACQ25Y  | 41 | 30 | 10.3 | 10 | 10.5 | M10×1.25 | 19 | 20 | -  | 20.2 | 2   | 8  | 10 | 1.1 | 26.4 |
| F-ACQ32Y  | 42 | 30 | 18.4 | 10 | 16   | M14×1.5  | 22 | 22 | 36 | 36.2 | 2   | 8  | 10 | 1.1 | 42.4 |
| F-ACQ50Y  | 56 | 40 | 22.4 | 14 | 20   | M18×1.5  | 28 | 28 | 44 | 44.2 | 2   | 12 | 14 | 1.1 | 50.4 |
| F-ACQ80Y  | 71 | 50 | 28.4 | 18 | 23   | M22×1.5  | 38 | 38 | 56 | 56.2 | 2   | 15 | 18 | 1.7 | 63.6 |
| F-ACQ100Y | 79 | 55 | 32.4 | 22 | 24   | M26×1.5  | 44 | 44 | 64 | 64.2 | 2.5 | 19 | 22 | 1.7 | 72.6 |

### I Knuckle

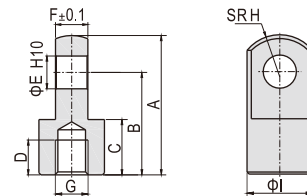

| Type/Item | A    | B  | C    | D   | E  | F    | G        | H    | I  |
|-----------|------|----|------|-----|----|------|----------|------|----|
| F-ACQ12I  | 21.5 | 16 | 9    | 6   | 5  | 4.7  | M5×0.8   | 6.3  | 10 |
| F-ACQ16I  | 32   | 25 | 11   | 8   | 5  | 6.2  | M6×1.0   | 8.1  | 12 |
| F-ACQ20I  | 34   | 25 | 13.5 | 8.5 | 8  | 7.7  | M8×1.25  | 10.3 | 16 |
| F-ACQ25I  | 41   | 30 | 16   | 11  | 10 | 9.7  | M10×1.25 | 12.8 | 20 |
| F-ACQ32I  | 42   | 30 | 16   | 14  | 10 | 17.6 | M14×1.5  | 12   | 22 |
| F-ACQ50I  | 56   | 40 | 20   | 18  | 14 | 21.6 | M18×1.5  | 16   | 28 |
| F-ACQ80I  | 71   | 50 | 23   | 21  | 18 | 27.6 | M22×1.5  | 21   | 38 |
| F-ACQ100I | 79   | 55 | 24   | 22  | 22 | 31.6 | M26×1.5  | 24   | 44 |